

HMR

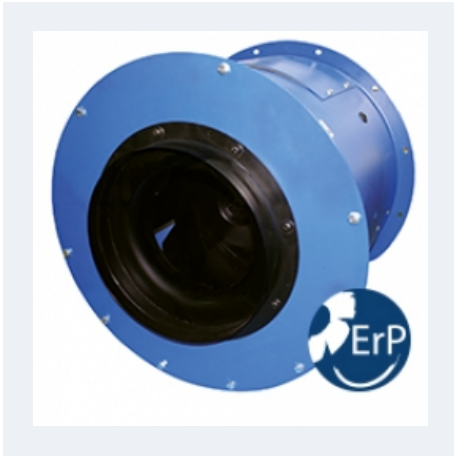

LONG CASED FAN WITH BACKWARD TURBINE

MANUFACTURING FEATURES:

- Reinforced fan casing manufactured in rolling steel sheet. Polyester powder finishing coat. Housing with motor access door.
- High efficiency backward impeller with self-cleaning system in steel sheet, balanced static and dynamically in origin.
- Standard asynchronous squirrel-cage motor with IP-55 protection and Class F insulation. Standard voltages 230/400V 50Hz .
- Maximum working temperature 60°C.

APPLICATIONS:

Designed for inline installation, they are suitable for:

- Air renewal in buildings and industries.
- Smoke extraction.

Accessories



FILTRO
EMC



INT



JE 45



PO



RP



SFC

Technical data

Three-phase motor / 2 poles

Code	Model	R.P.M.	Rated I. (A) 400V	Rated power kW	Max. Airflow m3/h	Sound db (A)**	Weight	Connect. diagram
261310620	HMR 315 T2 1,1kW	2800	2,33	1,10	4.400	53	64	1
261350620	HMR 355 T2 2,2kW	2800	4,58	2,20	6.740	56	60	1

Three-phase motor / 4 poles

Code	Model	R.P.M.	Rated I. (A) 400V	Rated power kW	Max. Airflow m3/h	Sound db (A)**	Weight	Connect. diagram
261310640	HMR 315 T4 0,25kW	1400	0,79	0,25	2.180	48	73	1
261350640	HMR 355 T4 0,55kW	1400	1,49	0,55	3.590	51	68	1
261400640	HMR 400 T4 0,75kW	1390	1,63	0,75	5.310	54	84	1
261450640	HMR 450 T4 1,1kW	1400	2,49	1,10	7.530	57	120	1
261500640	HMR 500 T4 1,5kW	1400	3,26	1,50	10.000	60	153	1
261560640	HMR 560 T4 3kW	1430	6,17	3	12.950	64	194	1
261630640	HMR 630 T4 4kW	1440	8,32	4	17.900	65	246	1

Three-phase motor / 6 poles

Code	Model	R.P.M.	Rated I. (A) 400V	Rated power kW	Max. Airflow m3/h	Sound db (A)**	Weight	Connect. diagram
261710660	HMR 710 T6 2,2kW	940	5,94	2,20	18.980	64	303	1
261800660	HMR 800 T6 4kW	960	9,46	4	24.950	68	363	1

Notes:

** Total sound pressure level at the point of maximum flow measured in dB(A) in the suction measured in free field at a distance of 6m from the source

Dimensions

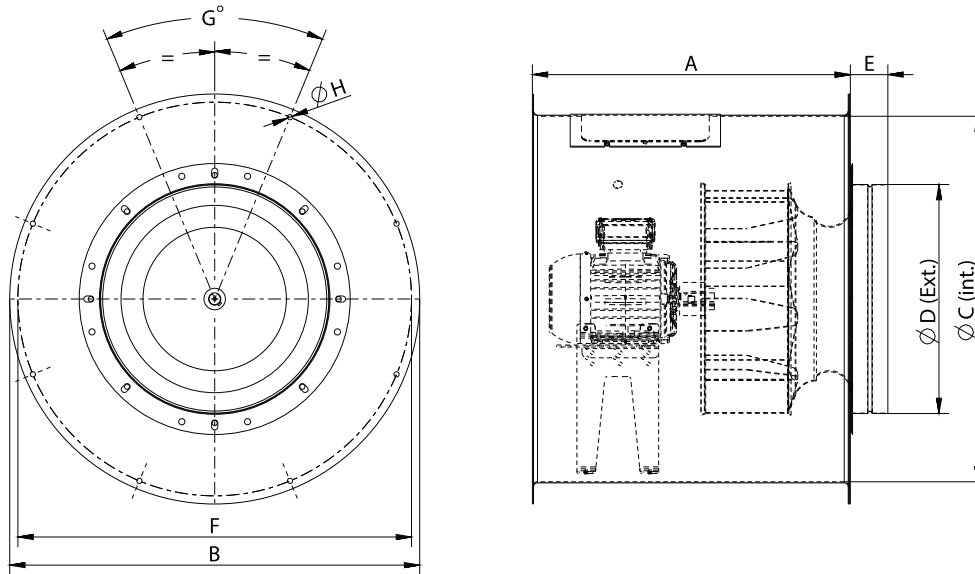

Model	A	E	G	ϕB	ϕC	ϕD	ϕF	ϕH
HMR 315 T2 1,1kW	482	70	6x60°	600	504	298	560	10,2
HMR 315 T4 0,25kW	482	70	6x60°	600	504	298	560	10,2
HMR 355 T2 2,2kW	562	70	6x60°	646	559	348	620	10,2
HMR 355 T4 0,55kW	562	70	6x60°	646	559	348	620	10,2
HMR 400 T4 0,75kW	567	70	6x60°	725	633	398	690	10,2
HMR 450 T4 1,1kW	622	70	8x45°	802	715	448	770	10,2
HMR 500 T4 1,5kW	664	70	8x45°	892	801	498	860	10,2
HMR 560 T4 3kW	714,5	70	8x45°	1000	903,5	548	970	10,2
HMR 630 T4 4kW	830	70	8x45°	1115	1013	628	1070	10,2
HMR 710 T6 2,2kW	890	70	8x45°	1234	1132	698	1190	10,2
HMR 800 T6 4kW	930	70	10x36°	1365	1263	798	1320	10,2

Wiring diagram

DIAGRAM Nº 1

230/400V

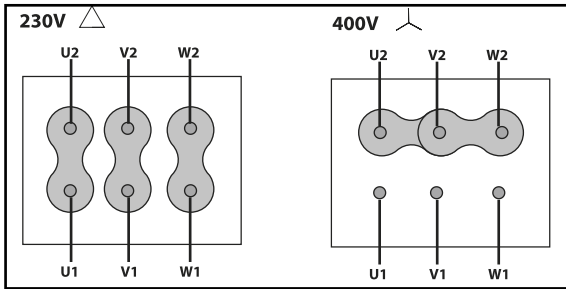

400/690V

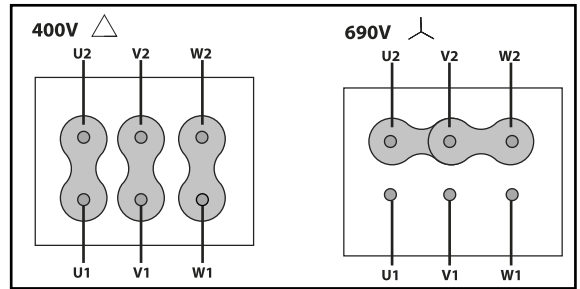

CHARACTERISTIC CURVE

1 HMR 315 T2 1,1kW

2 HMR 355 T2 2,2kW

AIR FLOW - PRESSURE

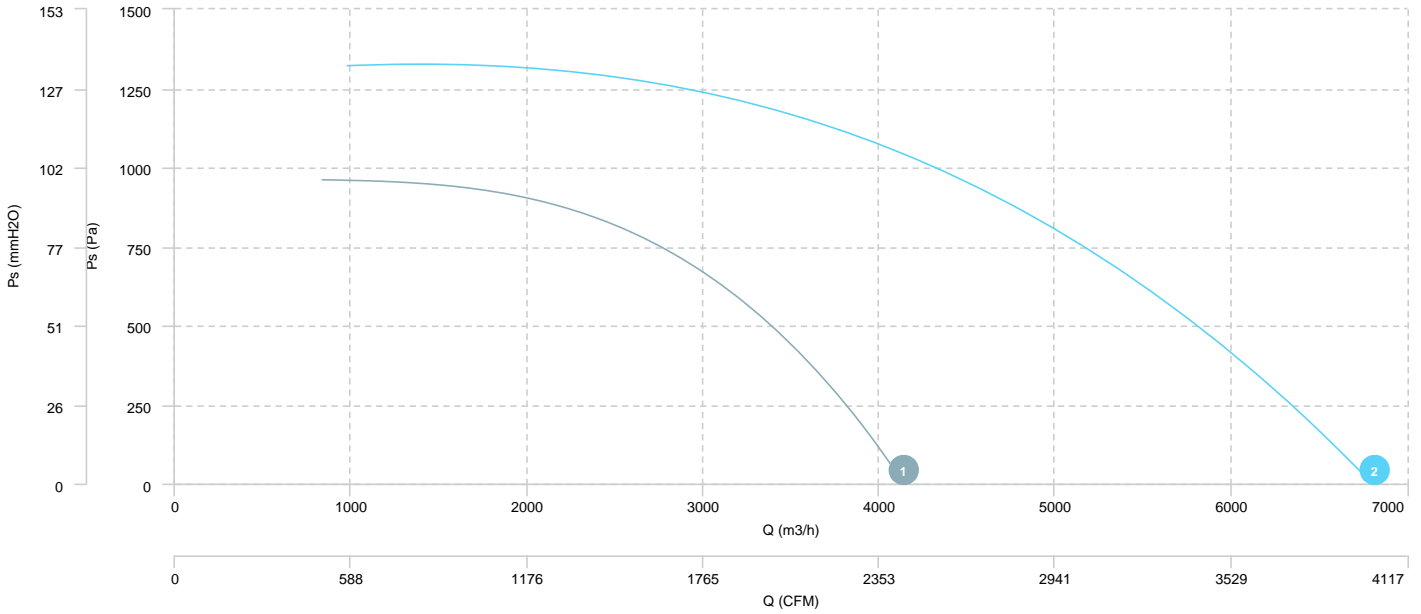

AIR FLOW - ABSORBED POWER

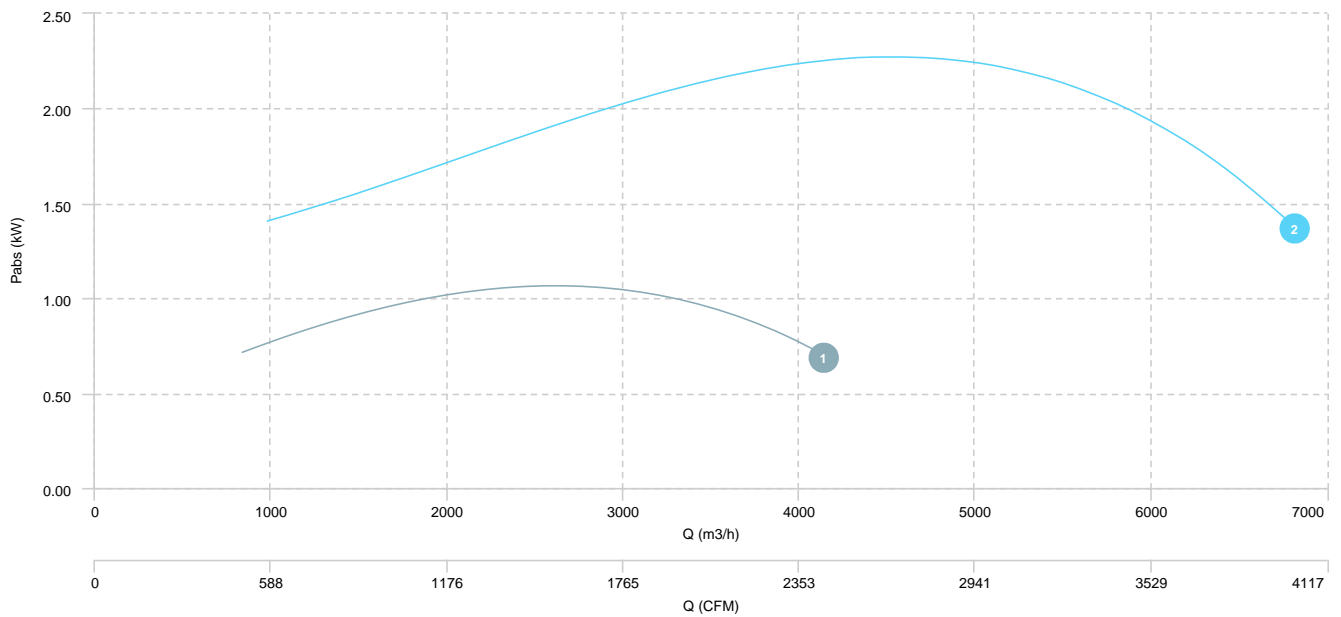

1	HMR 315 T4 0,25kW	2	HMR 355 T4 0,55kW	3	HMR 400 T4 0,75kW	4	HMR 450 T4 1,1kW
5	HMR 500 T4 1,5kW	6	HMR 560 T4 3kW	7	HMR 630 T4 4kW		

AIR FLOW - PRESSURE

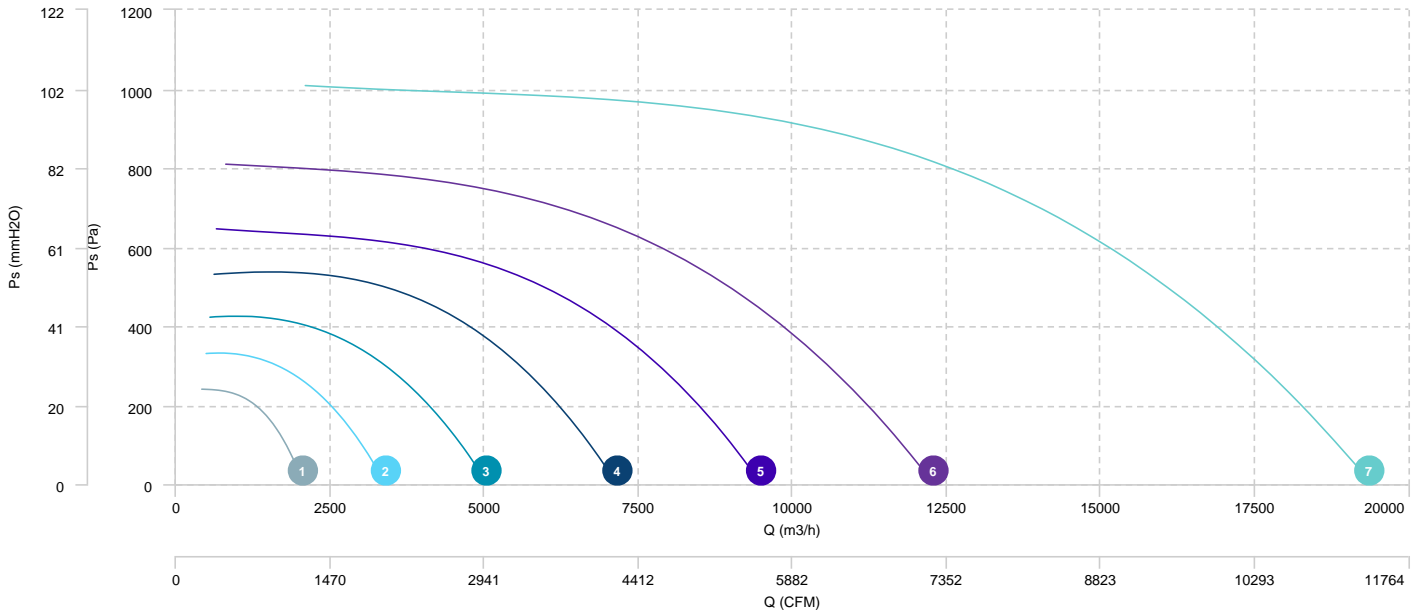

AIR FLOW - ABSORBED POWER

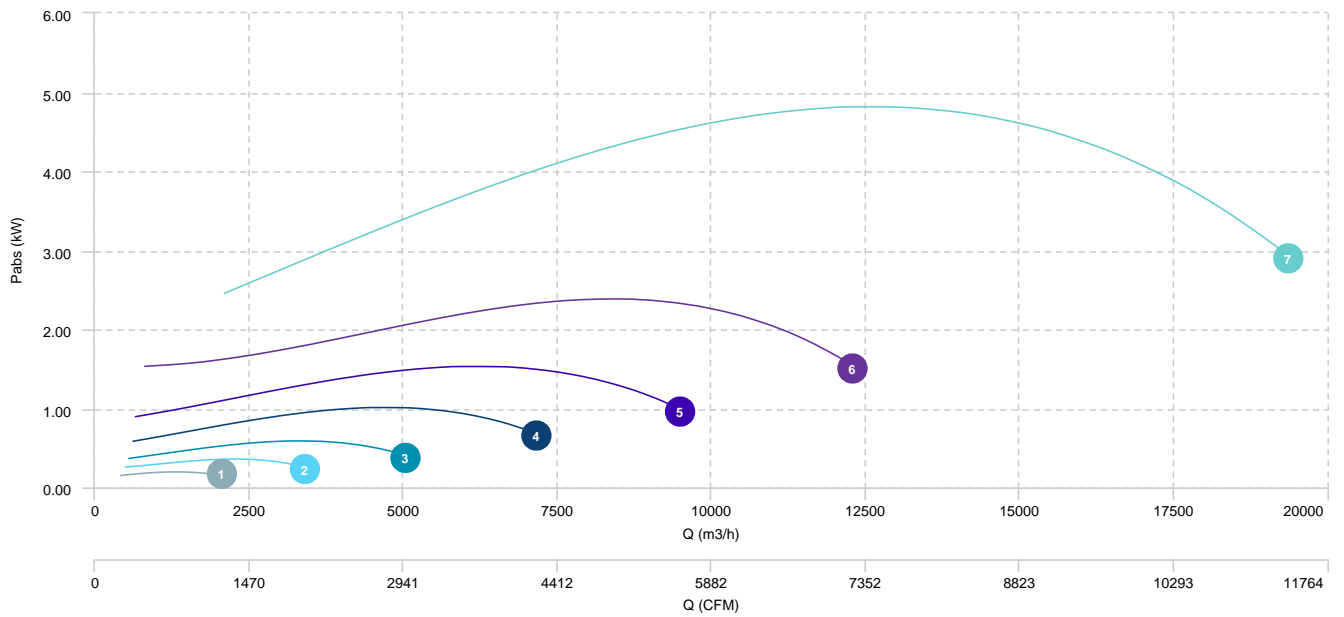

1 HMR 710 T6 2,2kW

2 HMR 800 T6 4kW

AIR FLOW - PRESSURE

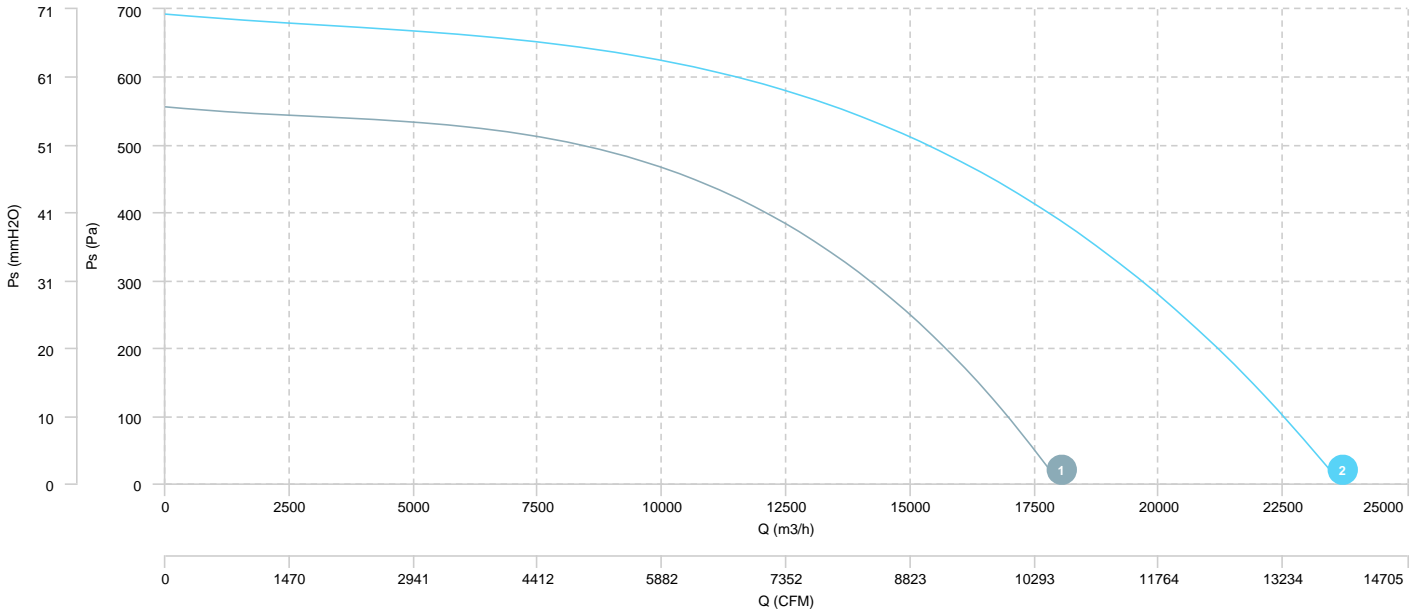

AIR FLOW - ABSORBED POWER

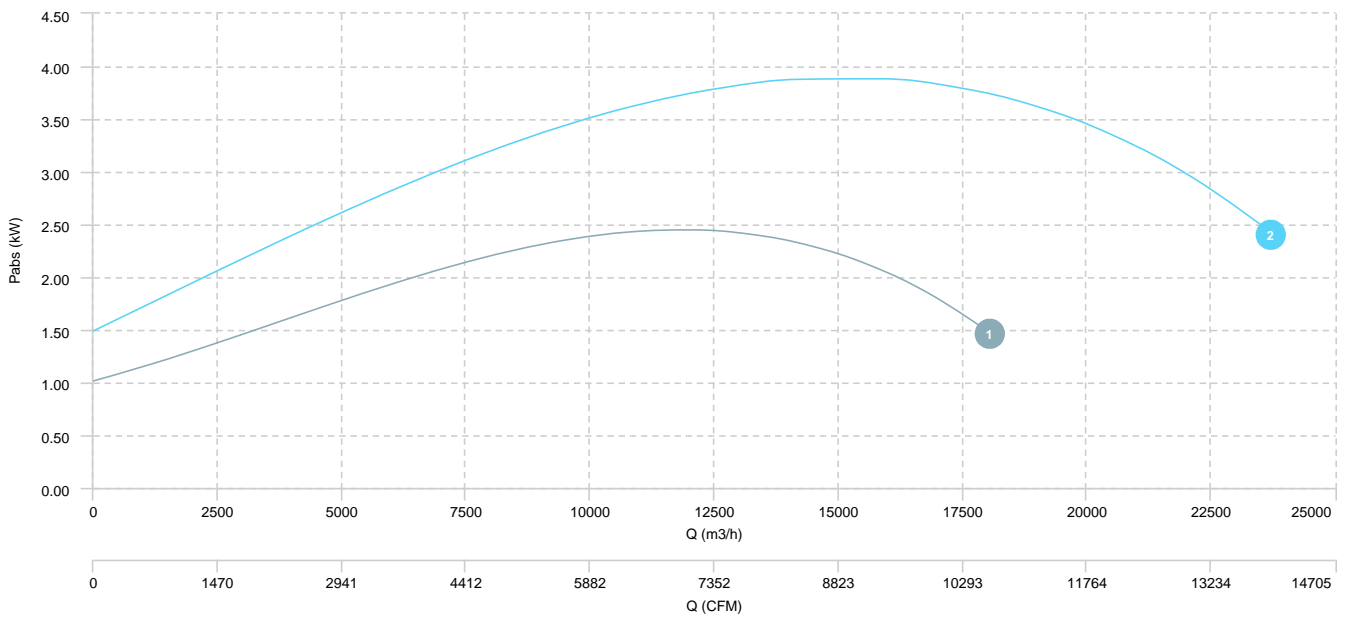

Sound data

Sound / 2 poles

Sound power Lw dB (A)										
Model		63 Hz	125 Hz	250 Hz	500 Hz	1000 Hz	2000 Hz	4000 Hz	8000 Hz	Total
HMR 315 T2 1,1kW	Inlet	52	71	72	70	71	72	70	56	79
HMR 355 T2 2,2kW	Inlet	55	74	75	73	74	75	73	59	82

Sound / 4 poles

Sound power Lw dB (A)										
Model		63 Hz	125 Hz	250 Hz	500 Hz	1000 Hz	2000 Hz	4000 Hz	8000 Hz	Total
HMR 315 T4 0,25kW	Inlet	52	60	64	68	69	67	64	59	74
HMR 355 T4 0,55kW	Inlet	55	63	67	71	72	70	67	62	77
HMR 400 T4 0,75kW	Inlet	58	66	70	74	75	73	70	65	80
HMR 450 T4 1,1kW	Inlet	61	69	73	76	78	76	73	68	83
HMR 500 T4 1,5kW	Inlet	63	71	76	79	80	79	75	70	86
HMR 560 T4 3kW	Inlet	68	76	81	84	85	83	80	75	90
HMR 630 T4 4kW	Inlet	67	88	85	71	85	82	74	70	91

Sound / 6 poles

Sound power Lw dB (A)										
Model		63 Hz	125 Hz	250 Hz	500 Hz	1000 Hz	2000 Hz	4000 Hz	8000 Hz	Total
HMR 710 T6 2,2kW	Inlet	68	76	80	84	85	83	80	75	90
HMR 800 T6 4kW	Inlet	72	80	84	87	89	87	84	78	94

erp data

ERP	
Fan type	Unit for non-residential ventilation (LOT 6)
Typology	Unidirectional
Others	None
Type of driver	None

ERP / 2 poles

Model	Motor power (kW)	Maximum efficiency point data						
		Eff.Heat recovery (%)	Max. efficiency (%)	Pabs (kW)	Air Flow (m3/h)	Ps (Pa)	Speed (m/s)	SFP (W/m3/s)
HMR 315 T2 1,1kW	1,1	-	56,37	1,06	2.714,96	762,22	9.68	1.411,16
HMR 355 T2 2,2kW	2,2	-	55,85	2,25	4.062,88	1.059,68	11.4	1.989,01

ERP / 4 poles

Model	Motor power (kW)	Maximum efficiency point data						
		Eff.Heat recovery (%)	Max. efficiency (%)	Pabs (kW)	Air Flow (m3/h)	Ps (Pa)	Speed (m/s)	SFP (W/m3/s)
HMR 315 T4 0,25kW	0,25	-	37,89	0,20	1.350,90	191,49	4.82	522,25
HMR 355 T4 0,55kW	0,55	-	43,60	0,36	2.057,23	262,04	5.77	623,34
HMR 400 T4 0,75kW	0,75	-	50,84	0,59	3.038,81	338,05	6.72	692,82
HMR 450 T4 1,1kW	1,1	-	55,06	1,01	4.335,36	438,83	7.57	835,28
HMR 500 T4 1,5kW	1,5	-	56,97	1,53	5.804,50	511,12	8.21	946,68
HMR 560 T4 3kW	3	-	58,40	2,34	7.271,44	641,70	8.2	1.158,28
HMR 630 T4 4kW	4	-	61,19	4,81	12.244,08	818,57	10.91	1.415,15

ERP / 6 poles

Model	Motor power (kW)	Maximum efficiency point data						
		Eff.Heat recovery (%)	Max. efficiency (%)	Pabs (kW)	Air Flow (m3/h)	Ps (Pa)	Speed (m/s)	SFP (W/m3/s)
HMR 710 T6 2,2kW	2,2	-	58,68	2,42	10.509,48	452,64	7.37	827,62
HMR 800 T6 4kW	4	-	58,14	3,86	13.825,32	546,58	7.64	1.006,00