

HMA EVO EEC



LONG CASED VARIABLE PITCH BLADES WITH EEC MOTOR

MANUFACTURING FEATURES

- Long cased axial fan with reinforced body, with double flange, made of rolling steel sheet.
- Pad mounted motor support system with guide vanes.
- Epoxy powder finishing coat.
- Low sound level and high performance.
- Electronic high performance permanent magnet motor EEC Probat by Casals.
- 100% controllable thanks to the control. Controlled by high efficiency drive.
- Cast aluminium impeller with variable pitch angle (Stopped and in origin).

APPLICATIONS

Designed for inline installation, they are suitable for:

- Air renewal in buildings and industries.
- Smoke extraction.
- Maximum working temperature 60°C.

UNDER REQUEST

- Casing in hot galvanized sheet or stainless steel.

Accessories



AC



BA-400



INT



PO



RP



SIL-C /
SIL-CN

Technical data

Single-phase motor

Code	Model	R.P.M.	Rated I. (A) 230V	Rated power kW	Max. Airflow m3/h	Sound db (A)**	Weight	Connect. diagram
276359040AEC	HMA EVO 35 EEC	2000	5	0,37	4.600	55	17	1
276409040AEC	HMA EVO 40 EEC	2000	6	0,75	6.120	57	19,50	1
276459040AEC	HMA EVO 45 EEC	2000	6	0,75	8.850	61	23	1
276509040AEC	HMA EVO 50 EEC	2000	10	1,50	10.250	59	31	1
276569540AEC	HMA EVO 56 EEC	1500	10	1,50	14.000	62	34,50	1
276639535AEC	HMA EVO 63 EEC	1500	10	1,50	18.900	65	43	1

Notes:

** Total sound pressure level at the point of maximum flow measured in dB(A) in the suction measured in free field at a distance of 6m from the source

Dimensions

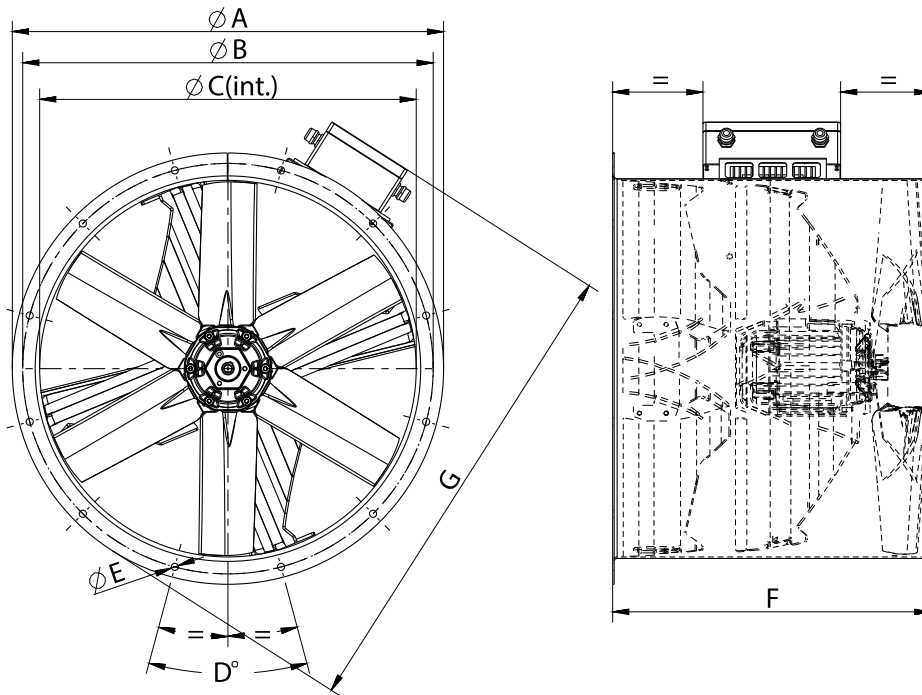

Model	A	B	C	D	E	F	G
HMA EVO 35 EEC	434	395	365	8x45	10	350	521
HMA EVO 40 EEC	472	450	472	8x45	10	350	563
HMA EVO 45 EEC	525	500	452	8x45	12	350	617
HMA EVO 50 EEC	600	560	504	12x30	12	350	675
HMA EVO 56 EEC	646	620	559	12x30	12	350	727
HMA EVO 63 EEC	725	690	633	12x30	12	350	806

Wiring diagram

DIAGRAM N° 1

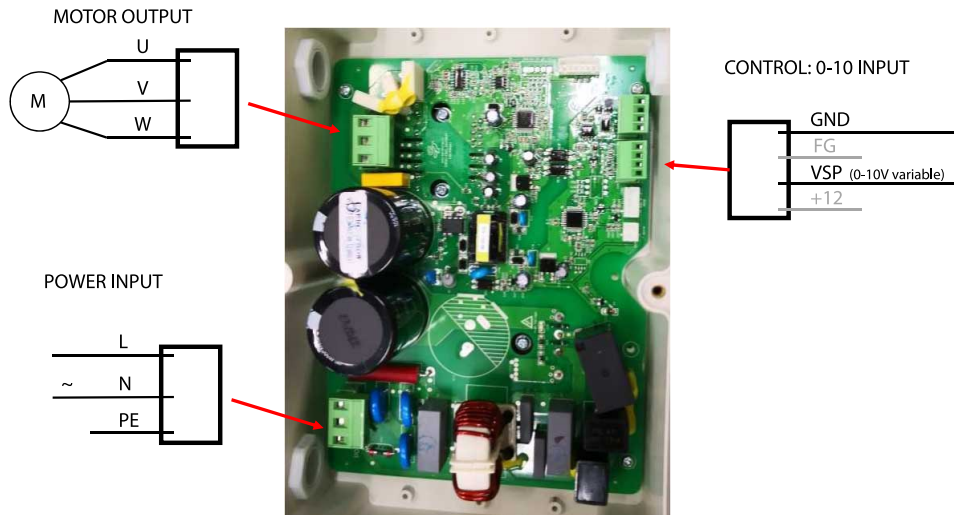

CHARACTERISCTIC CURVE

HMA EVO 35 EEC

AIR FLOW - PRESSURE

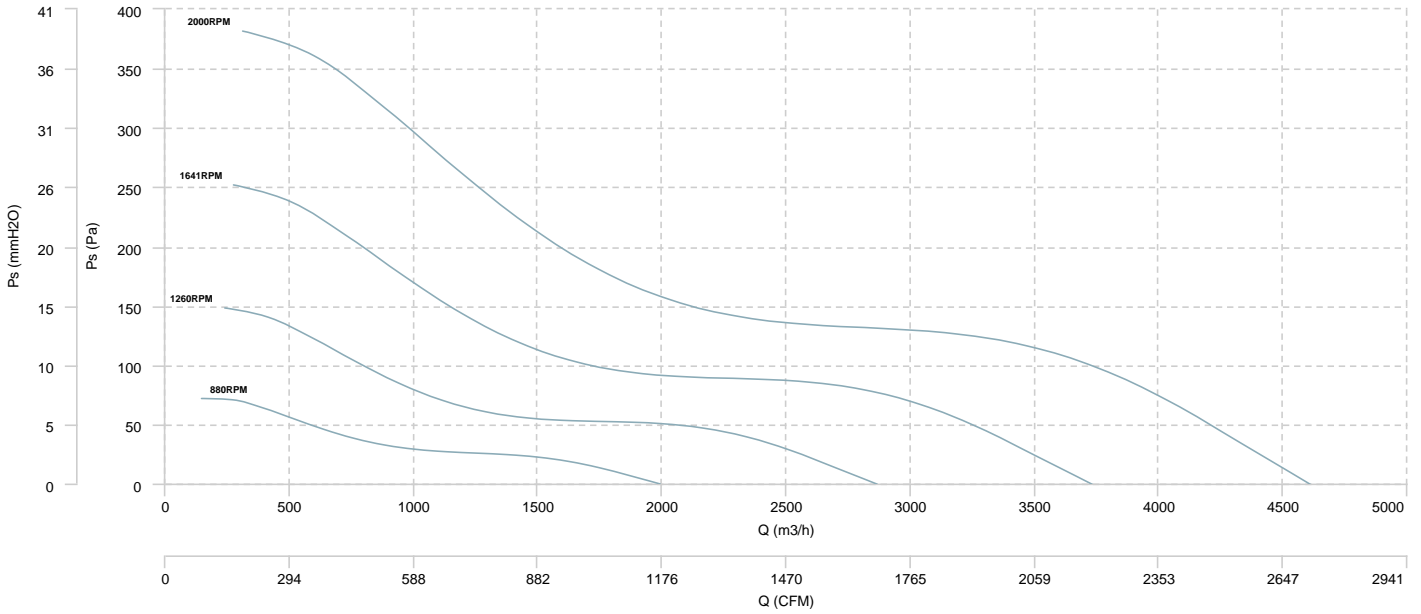

AIR FLOW - MECHANICAL POWER

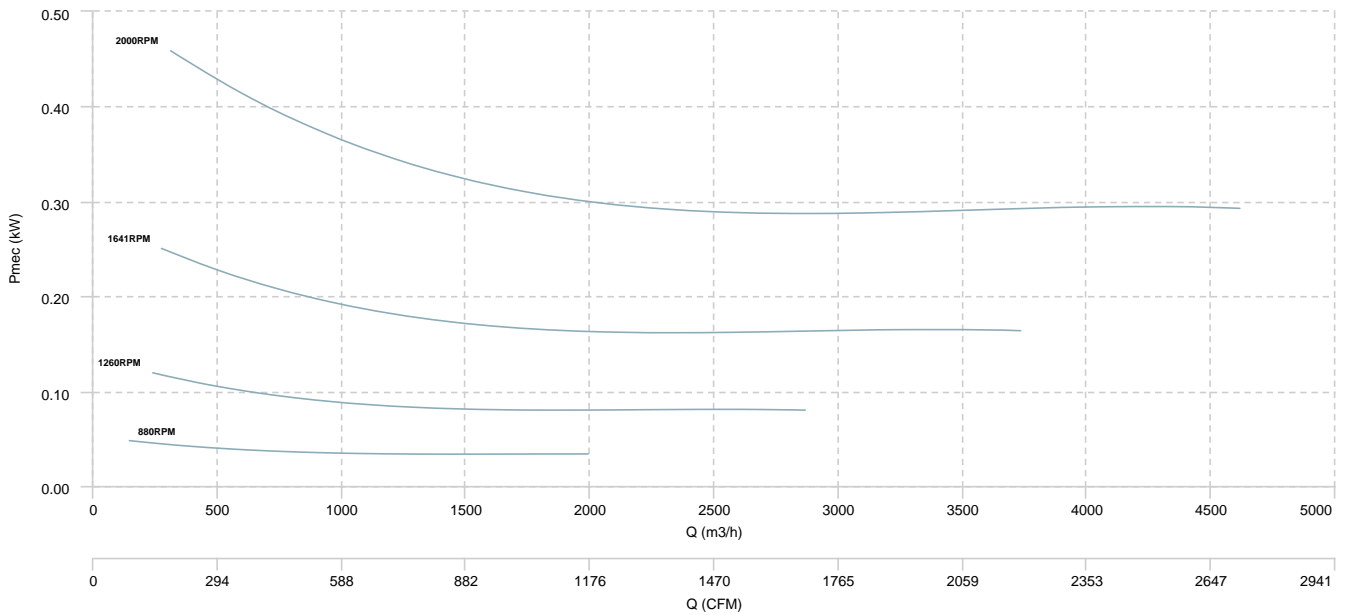

HMA EVO 40 EEC

AIR FLOW - PRESSURE

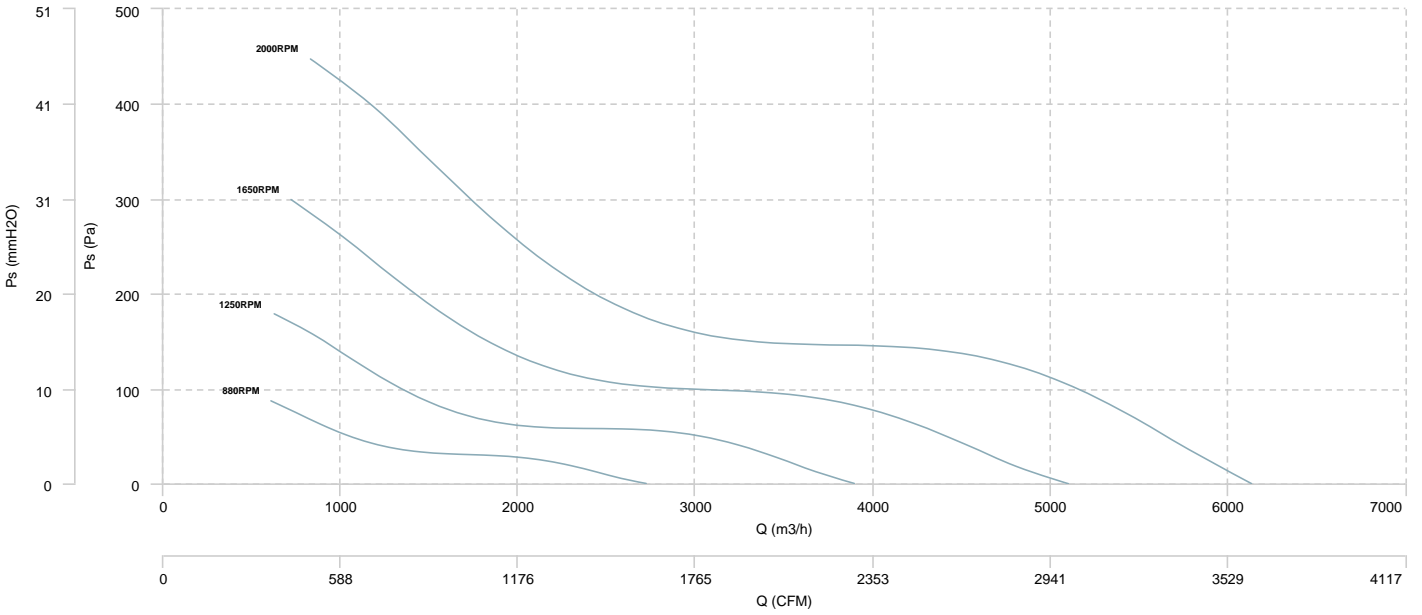

AIR FLOW - MECHANICAL POWER

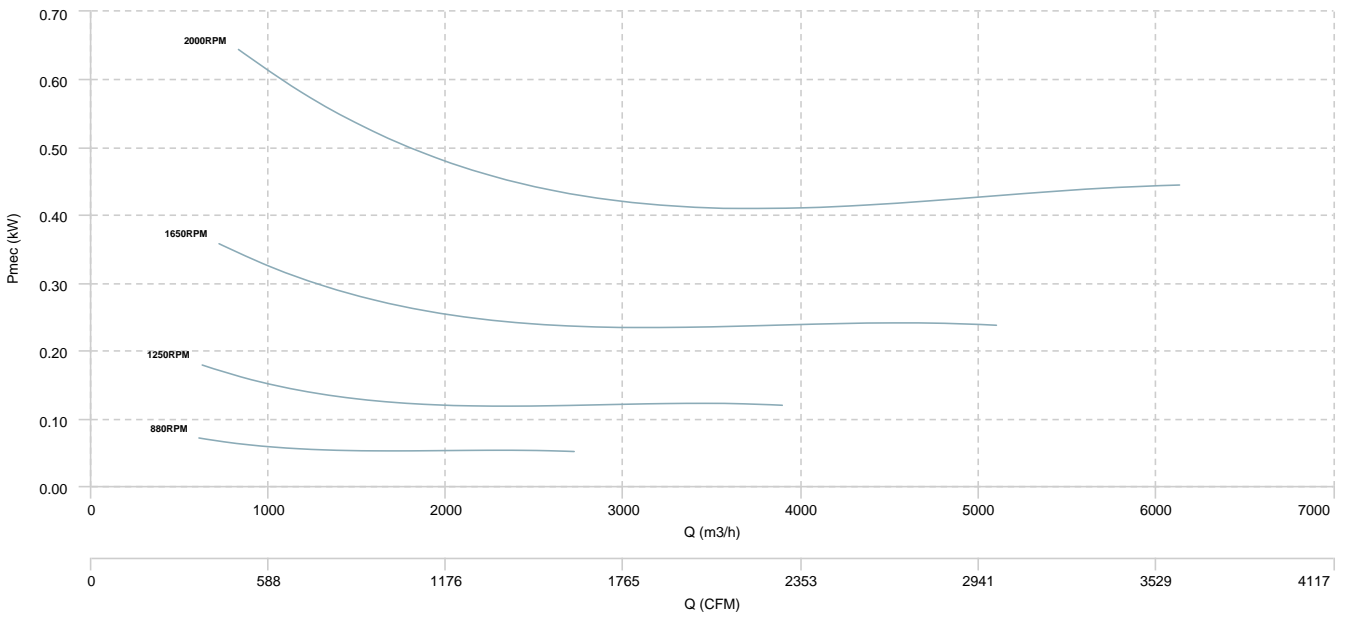

HMA EVO 45 EEC

AIR FLOW - PRESSURE

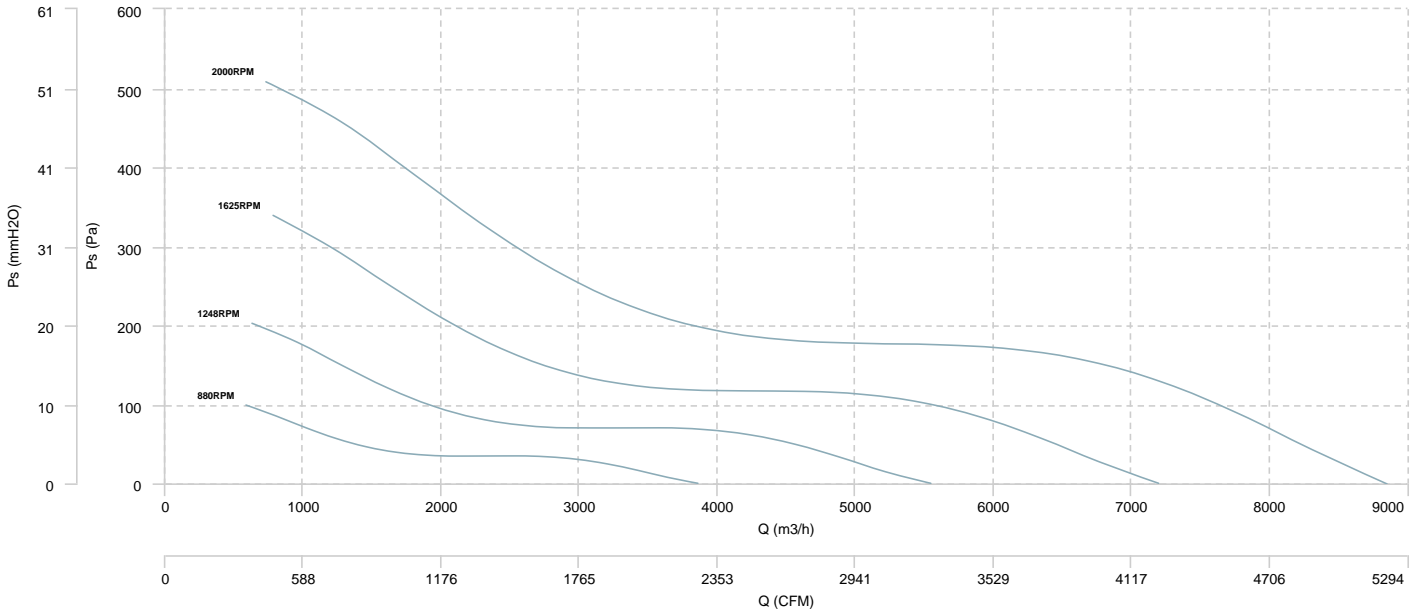

AIR FLOW - MECHANICAL POWER

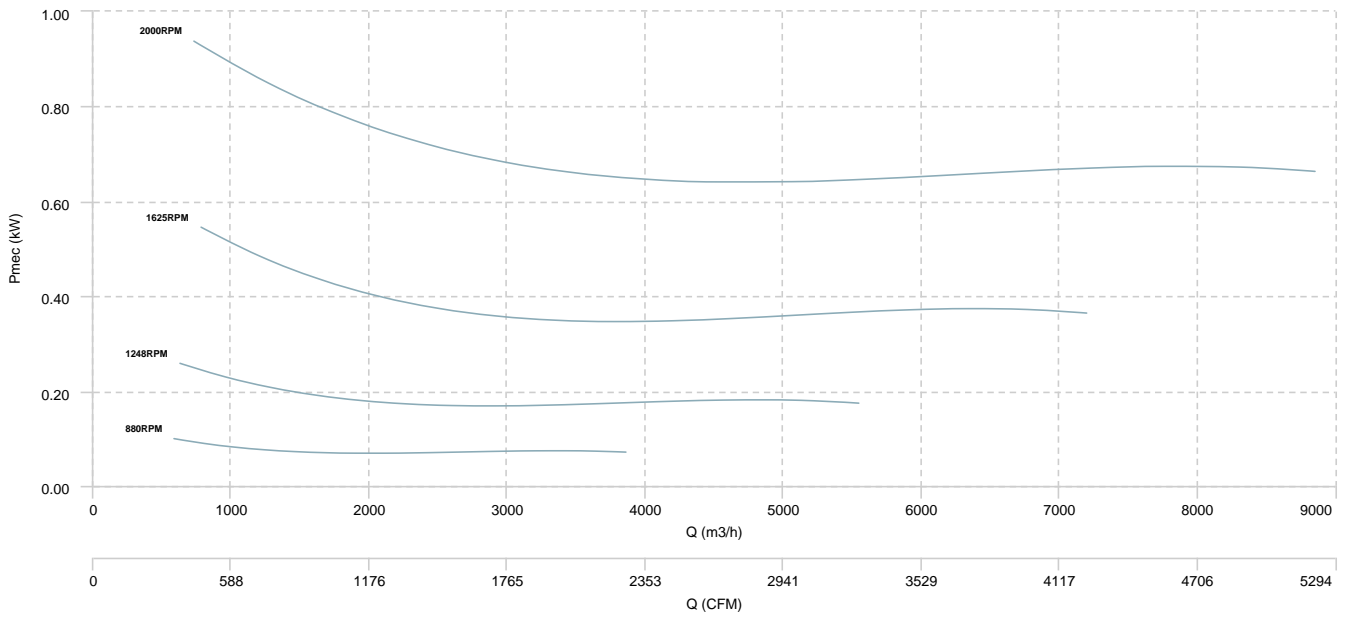

HMA EVO 50 EEC

AIR FLOW - PRESSURE

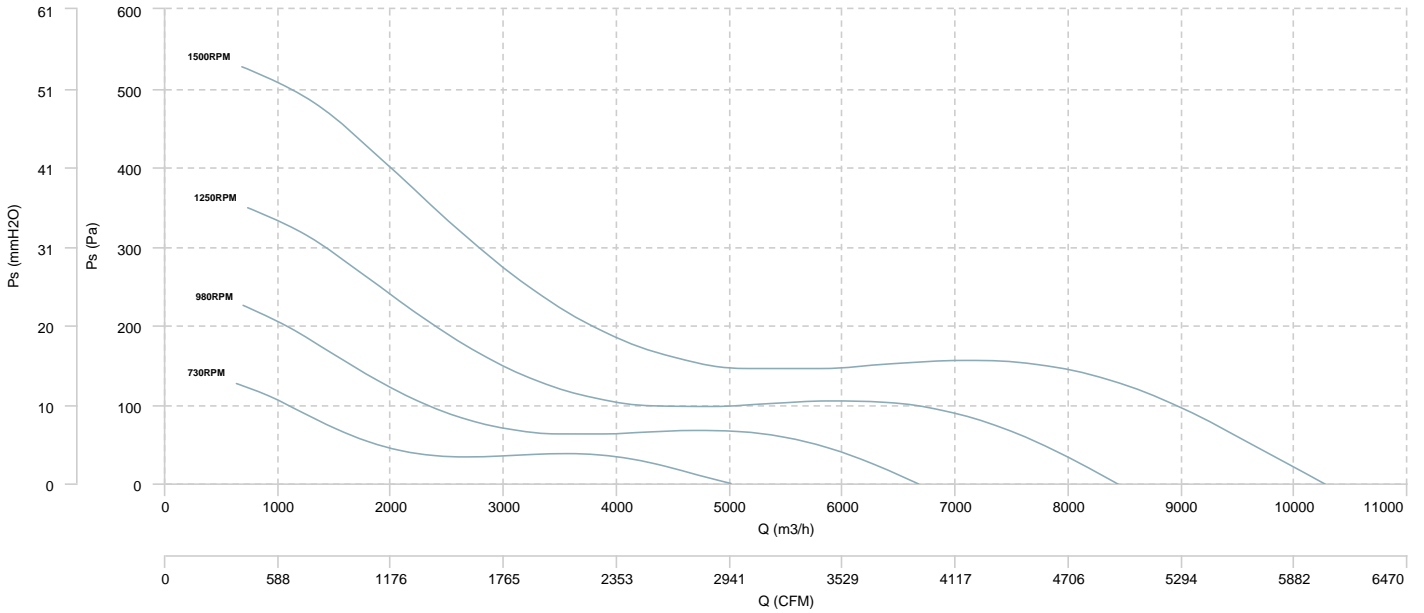

AIR FLOW - MECHANICAL POWER

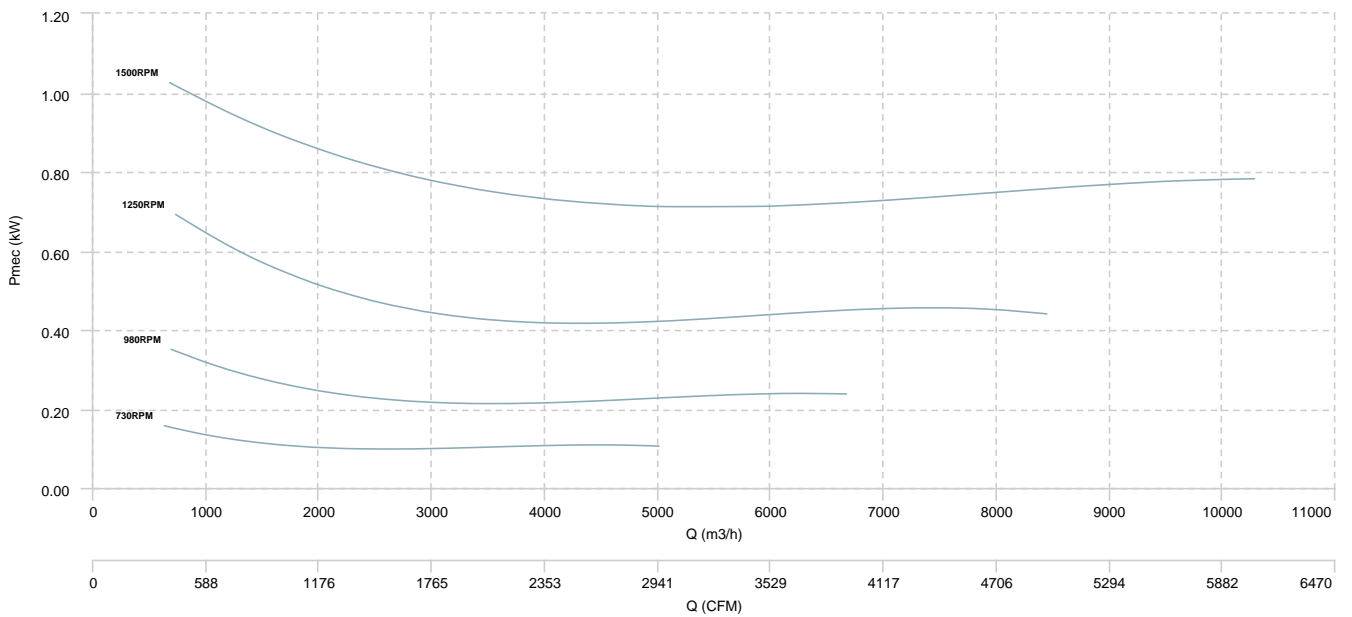

HMA EVO 56 EEC

AIR FLOW - PRESSURE

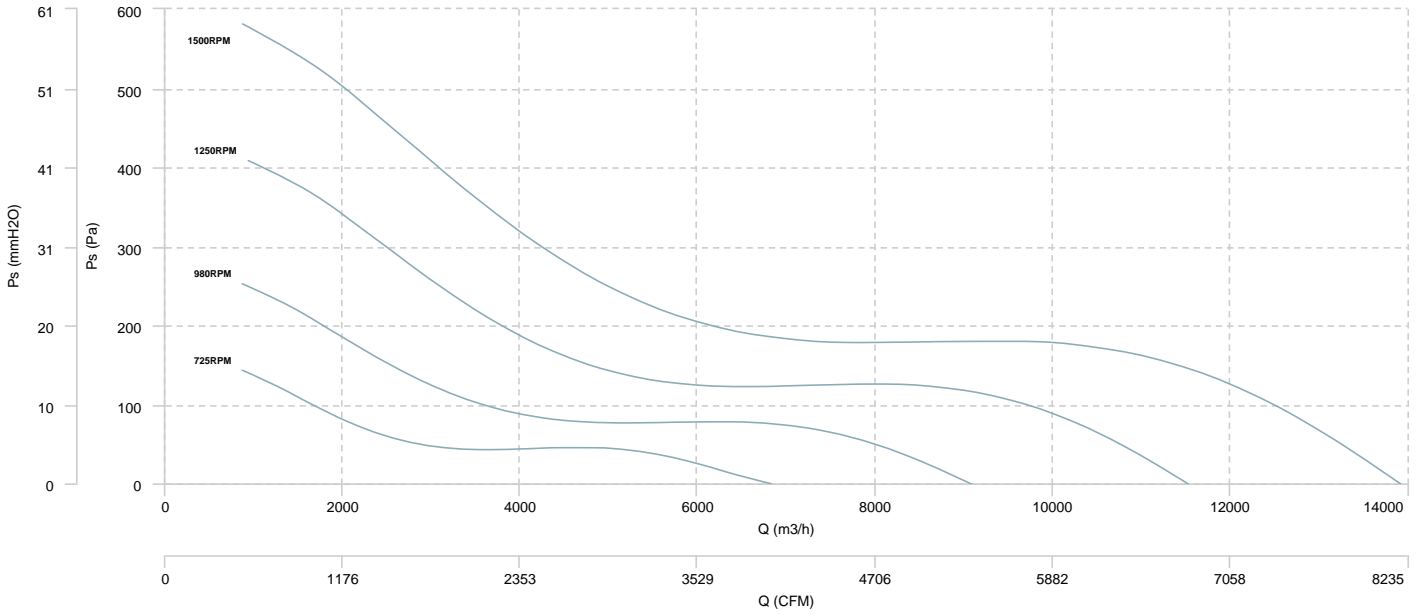

AIR FLOW - MECHANICAL POWER

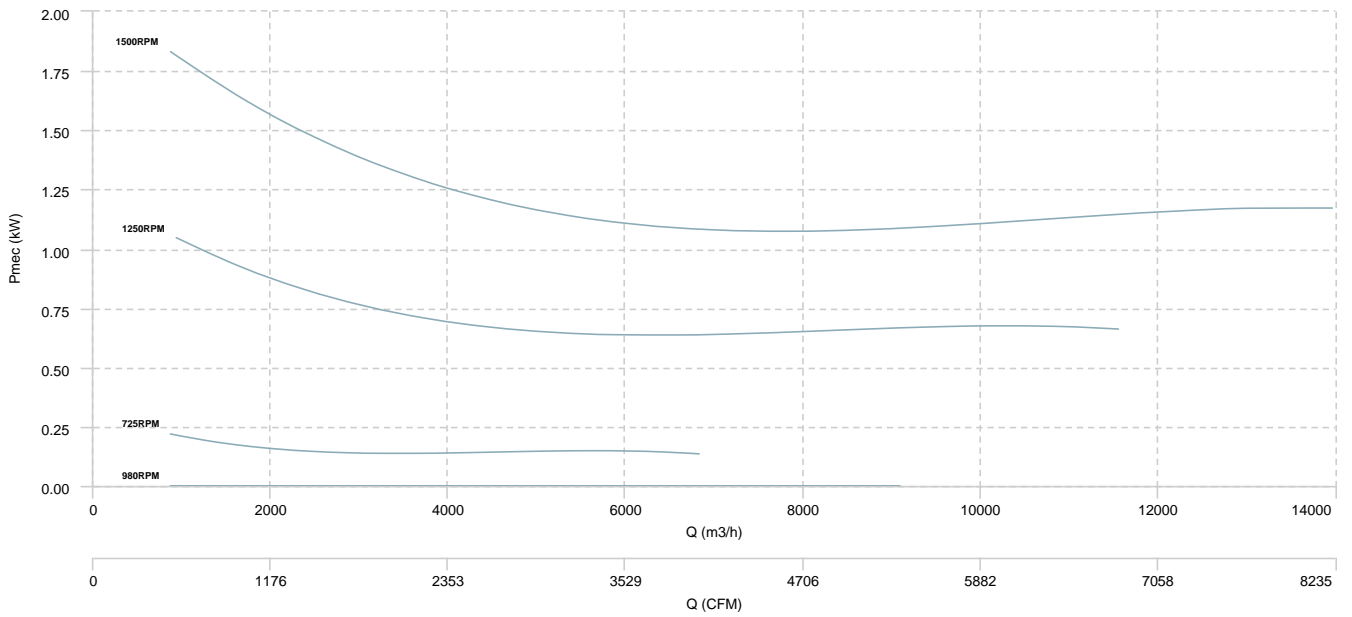

HMA EVO 63 EEC

AIR FLOW - PRESSURE

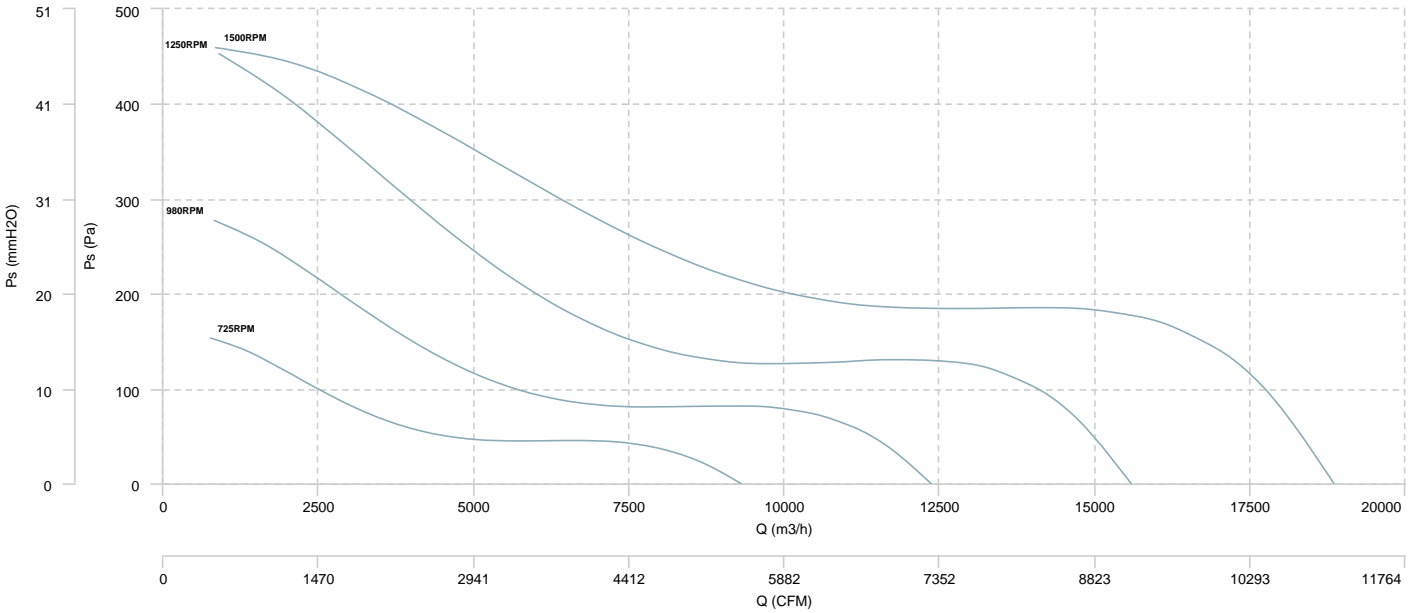

AIR FLOW - MECHANICAL POWER

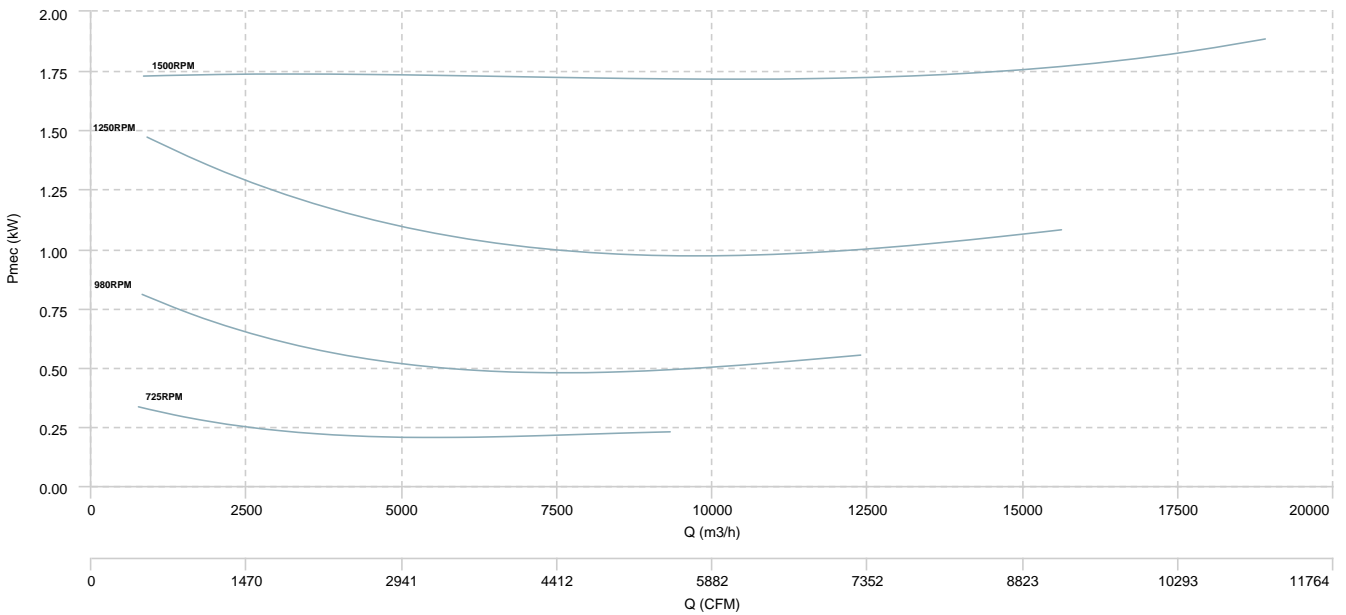

Sound data

Sound power Lw dB (A)										
Model		63 Hz	125 Hz	250 Hz	500 Hz	1000 Hz	2000 Hz	4000 Hz	8000 Hz	Total
HMA EVO 35 EEC (2000 RPM)	Inlet	72	77	76	71	68	62	57	52	81
HMA EVO 40 EEC (2000 RPM)	Inlet	81	77	70	65	64	61	58	53	83
HMA EVO 45 EEC (2000 RPM)	Inlet	78	83	82	77	74	68	63	58	87
HMA EVO 50 EEC (1500 RPM)	Inlet	83	79	72	67	66	63	60	55	85
HMA EVO 56 EEC (1500 RPM)	Inlet	86	82	75	70	69	66	63	58	88
HMA EVO 63 EEC (1500 RPM)	Inlet	89	85	78	73	72	69	66	61	91

Notes:

* To calculate the sound power level at different rpm from those indicated above, use the following formula:

$$Lw\ dB(A)_{rpmA} = Lw\ dB(A)_{rpmB} + 52.5 \cdot \log_{10} \frac{rpmA}{rpmB}$$