

HHX



EXTERNAL MOTOR, VARIABLE PITCH BLADES, ATEX

MANUFACTURING FEATURES:

- Long cased fan.
- Transmission ball bearings set inside a sealed box manufactured in steel or cast aluminium. Ball bearings permanently greased.
- Cast aluminium impeller with variable pitch angle in origin.
- Polyester powder finishing coat.
- Standard asynchronous squirrel-cage motor with IP-55 protection and Class F insulation. Manufactured with standard voltages: 230V 50Hz in single phase motors and 230/400V 50Hz in three phase motors, up to 4kW and 400/690V 50Hz for higher powers. EEx_d II2G classification.
- Inspection door located on the lower part of the housing.
- ATEX zone 1,2,22 construction.

Accessories



INT



RP



SFC

APPLICATIONS:

Designed for inline installation, they are suitable for:

- Air renewal in buildings and industries.
- Extraction of hot air up to 110°C.
- Maximum working temperature: carried air: 110°C, ambient 60°C.

UNDER REQUEST:

- Supply impeller (air direction from impeller to motor),
- Reversible impeller.
- Polyamide impeller.
- Hot-dipped galvanised or stainless steel housing.

ORGANISM: L.O.M.

CERTIFICATE N°: LOM 17.755X-C

In compliance with the ATEX Directive 2014/34/UE. Certified ATEX II2G, II3G or II3D with certified ATEX motor for areas 1 (gas), 2 (gas) or 22 (dust)

Technical data

Three-phase motor / 2 poles

Code	Model	R.P.M.	Rated I. (A) 400V	Rated power kW	Max. Airflow m3/h	Sound db (A)**	Weight	Connect. diagram
264100106XD	HHX 35 T2 0,55kW	2800	1,45	0,55	4.100	64	22	1

Three-phase motor / 4 poles

Code	Model	R.P.M.	Rated I. (A) 400V	Rated power kW	Max. Airflow m3/h	Sound db (A)**	Weight	Connect. diagram
264310106XD	HHX 35 T4 0,12kW	1400	0,71	0,12	3.150	48	20	1
264340120XD	HHX 45 T4 0,37kW	1400	1,2	0,37	6.290	49	36	1
264380106XD	HHX 56 T4 0,55kW	1400	1,75	0,55	8.680	56	36	1
264380120XD	HHX 56 T4 0,75kW	1390	2,1	0,75	10.940	56	36	1
264390106XD	HHX 56 T4 1,1kW	1400	3,3	1,10	12.040	56	39	1
264400106XD	HHX 63 T4 1,1kW	1400	3,3	1,10	14.010	56	59	1
264420106XD	HHX 71 T4 1,1kW	1400	3,3	1,10	15.970	70	74	1
264420120XD	HHX 71 T4 1,5kW	1400	3,8	1,50	18.980	62	77	1
264440106XD	HHX 90 T4 3kW	1430	6,8	3	29.940	77	113	1
264450106XD	HHX 90 T4 5,5kW	1440	11,5	5,50	32.510	78	132	1

Notes:

** Total sound pressure level at the point of maximum flow measured in dB(A) in the suction measured in free field at a distance of 6m from the source

Dimensions

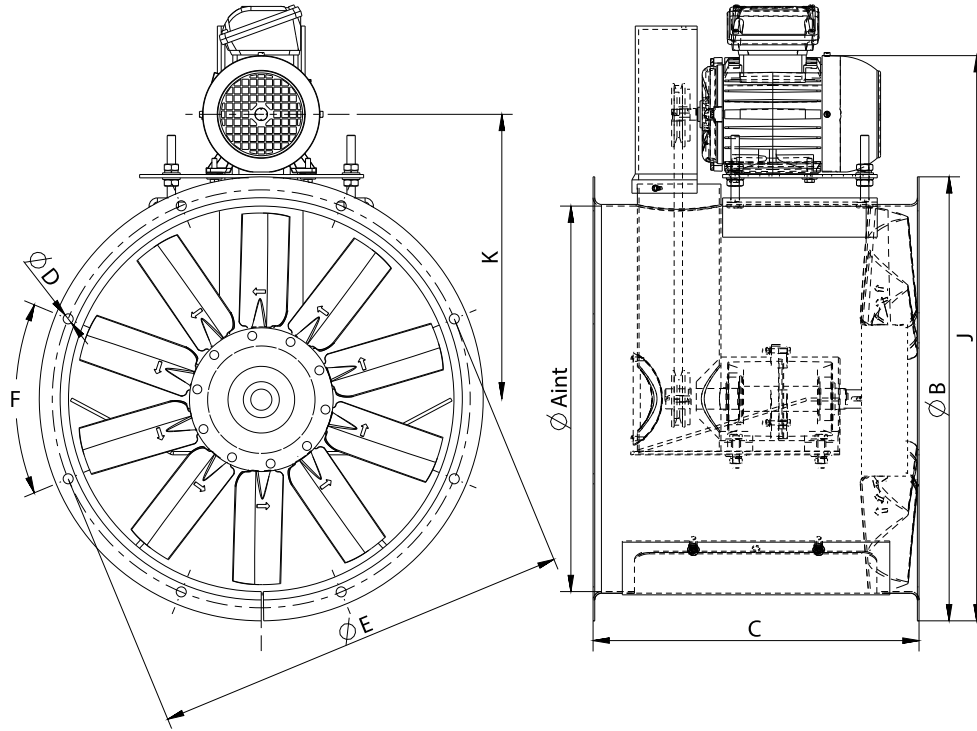

Model	A	B	C	D	E	F	J màx	K màx
HHX 35 T2 0,55kW	360	420	390	10	395	8x45°	540	254
HHX 35 T4 0,12kW	360	420	390	10	395	8x45°	540	254
HHX 45 T4 0,37kW	460	530	390	12	500	8x45°	720	355
HHX 56 T4 0,55kW	560	650	390	12	620	12x30°	858	406
HHX 56 T4 0,75kW	560	650	390	12	620	12x30°	858	406
HHX 56 T4 1,1kW	560	650	390	12	620	12x30°	858	406
HHX 63 T4 1,1kW	630	720	450	12	690	12x30°	950	430
HHX 71 T4 1,1kW	715	800	450	12	770	16x22,5°	975	478
HHX 71 T4 1,5kW	715	800	450	12	770	16x22,5°	975	478
HHX 90 T4 3kW	905	1002	550	12	970	16x22,5°	1320	652
HHX 90 T4 5,5kW	905	1002	550	12	970	16x22,5°	1320	652

Wiring diagram

DIAGRAM Nº 1

230/400V

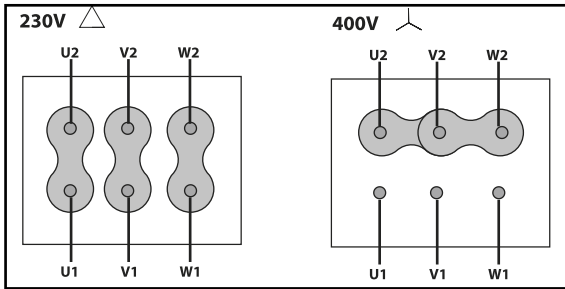

400/690V

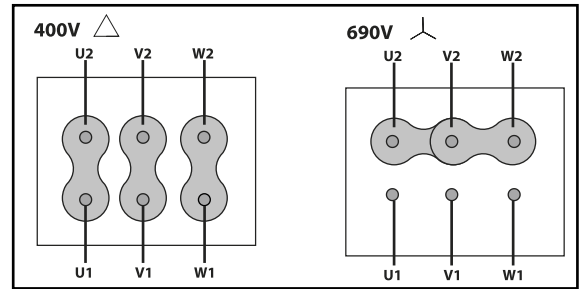

CHARACTERISCTIC CURVE

1 HHX 35 T2 0,55kW

AIR FLOW - PRESSURE

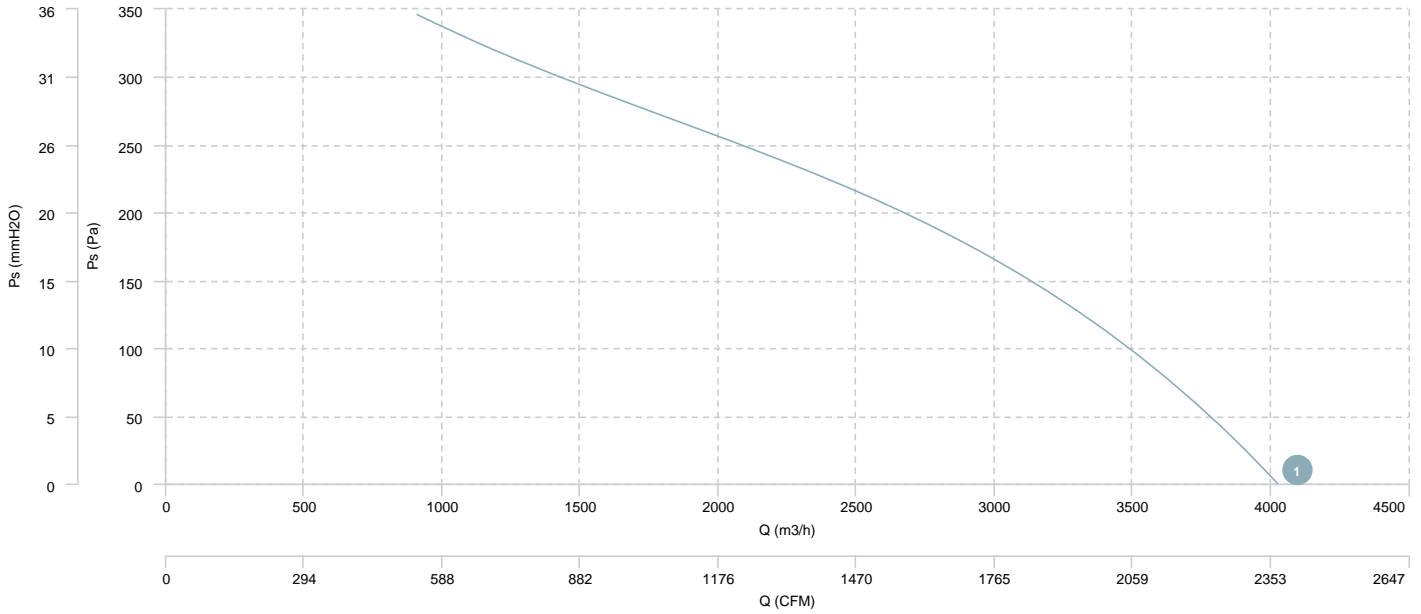

1	HHX 35 T4 0,12kW	2	HHX 45 T4 0,37kW	3	HHX 56 T4 0,55kW	4	HHX 56 T4 0,75kW
5	HHX 56 T4 1,1kW	6	HHX 63 T4 1,1kW	7	HHX 71 T4 1,1kW	8	HHX 71 T4 1,5kW
9	HHX 90 T4 3kW	10	HHX 90 T4 5,5kW				

AIR FLOW - PRESSURE

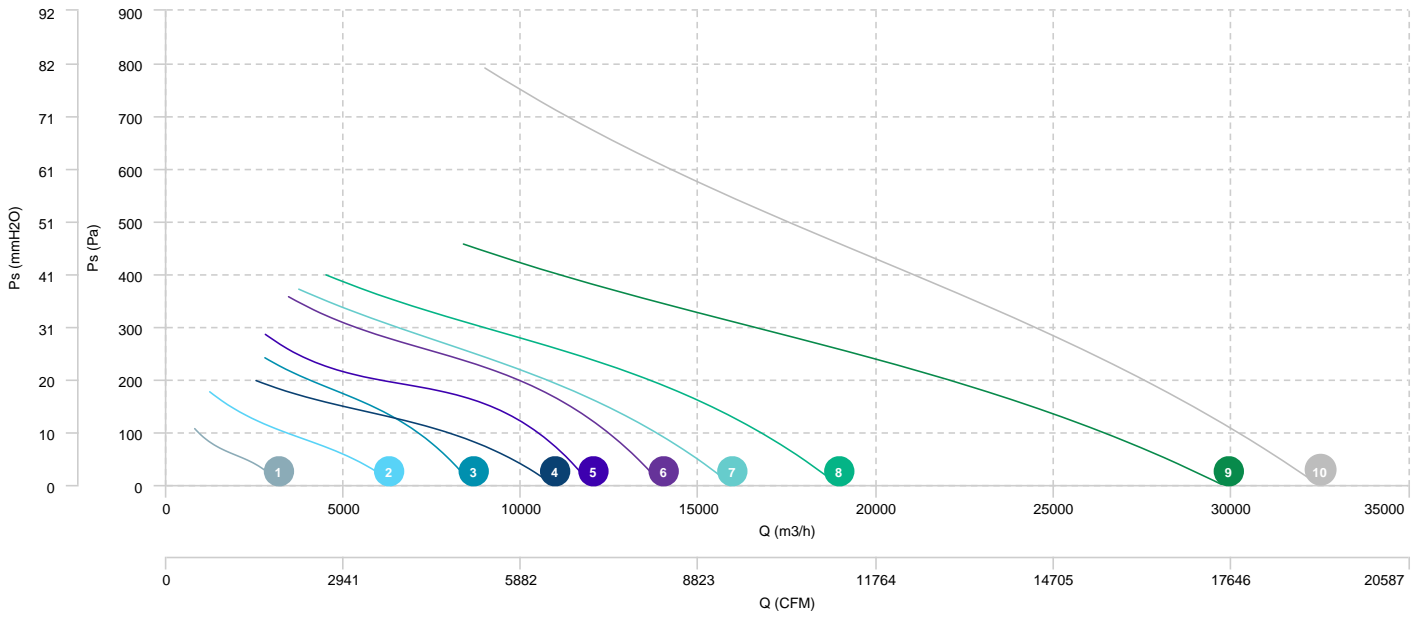

Sound data

Sound / 2 poles

Sound power Lw dB (A)										
Model		63 Hz	125 Hz	250 Hz	500 Hz	1000 Hz	2000 Hz	4000 Hz	8000 Hz	Total
HHX 35 T2 0,55kW	Inlet	49	67	79	84	86	80	73	68	90

Sound / 4 poles

Sound power Lw dB (A)										
Model		63 Hz	125 Hz	250 Hz	500 Hz	1000 Hz	2000 Hz	4000 Hz	8000 Hz	Total
HHX 35 T4 0,12kW	Inlet	34	52	64	69	71	65	58	53	74
HHX 45 T4 0,37kW	Inlet	46	54	60	65	68	66	69	63	75
HHX 56 T4 0,55kW	Inlet	51	59	67	74	76	77	78	73	82
HHX 56 T4 0,75kW	Inlet	54	61	66	72	74	76	77	71	82
HHX 56 T4 1,1kW	Inlet	53	60	66	72	74	76	77	72	82
HHX 63 T4 1,1kW	Inlet	52	59	64	72	77	74	79	71	82
HHX 71 T4 1,1kW	Inlet	59	69	85	92	90	84	84	76	96
HHX 71 T4 1,5kW	Inlet	59	64	72	79	83	80	83	74	88
HHX 90 T4 3kW	Inlet	64	81	93	98	98	94	88	80	103
HHX 90 T4 5,5kW	Inlet	66	83	95	99	99	96	90	81	104