

## BT ROOF 2 SB



### CENTRIFUGAL ROOF FAN WITH BACKWARD IMPELLER. HORIZONTAL DISCHARGE

#### MANUFACTURING FEATURES:

- Fan casing made of steel.
- Housing protected with polyester finishing coat.
- Electrical connection in external box.
- Backward impeller with self-cleaning system, directly coupled.
- Variable speed by voltage.
- Asynchronous external rotor with thermal protector. IP-54 protection. Standard voltages single phase motor 230V 50/60Hz.

#### APPLICATIONS

Specially designed for roof installation, they are suitable for:

- Air renewal in bathrooms and small closed environments.
- Maximum working temperature: 50°C.

#### VERSIONS

- BT ROOF 2 SB : Without flanges on the base
- BT ROOF 2 SBP : With flanges on the base

## Accessories



INT



REG



REG  
VMC



REGD

## Technical data

### Single-phase motor

Code	Model	R.P.M.	Rated I. (A) 230V	Rated power kW	Max. Airflow m <sup>3</sup> /h	Sound db (A)**	Weight	Connect. diagram
509301500	BT ROOF 2 150 SB	2705	0,43	0,10	560	45	8,20	1
509301500P	BT ROOF 2 150 SBP	2705	0,43	0,10	560	45	8,20	1
509302000	BT ROOF 2 200 SB	2375	0,67	0,15	950	51	9,30	1
509302000P	BT ROOF 2 200 SBP	2375	0,67	0,15	950	51	9,30	1
509302500	BT ROOF 2 250 SB	2790	0,85	0,19	1.310	48	12,30	1
509302500P	BT ROOF 2 250 SBP	2790	0,85	0,19	1.310	48	12,30	1
509303150	BT ROOF 2 315 SB	2720	1,34	0,30	1.880	51	13,20	1
509303150P	BT ROOF 2 315 SBP	2720	1,34	0,30	1.880	51	13,20	1

**Notes:**

\*\* Total sound pressure level at the point of maximum flow measured in dB(A) in the suction measured in free field at a distance of 6m from the source

## Dimensions

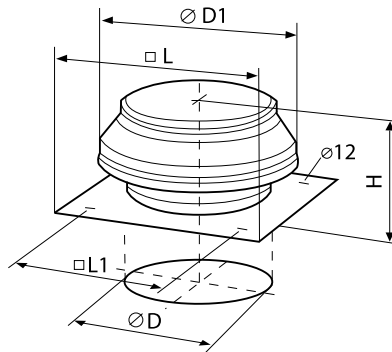

Model	H	L	L1	ØD	ØD1
BT ROOF 2 150 SB	230	440	330	149	400
BT ROOF 2 200 SB	250	440	330	198	400
BT ROOF 2 250 SB	249	590	450	248	400
BT ROOF 2 315 SB	269	590	450	315	500

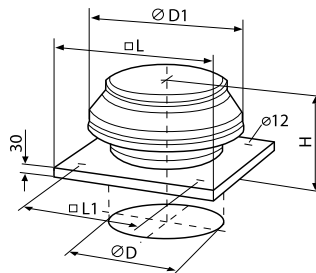

Model	H	L	L1	ØD	ØD1
BT ROOF 2 150 SBP	230	440	330	149	400
BT ROOF 2 200 SBP	250	440	330	198	400
BT ROOF 2 250 SBP	249	590	450	248	400
BT ROOF 2 315 SBP	269	590	450	315	500

## Wiring diagram

DIAGRAM N° 1

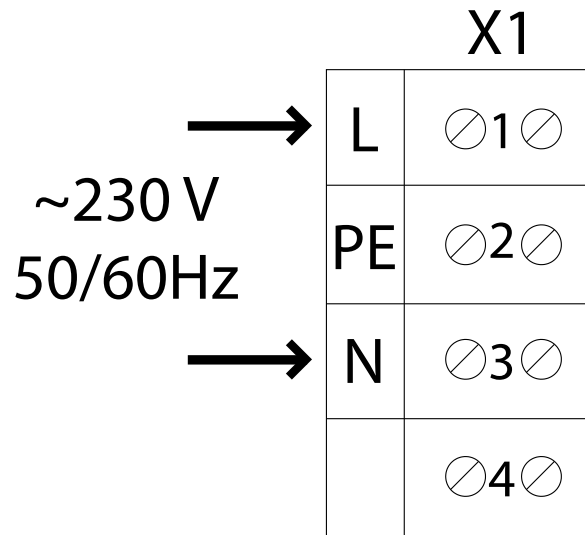

# CHARACTERISTIC CURVE

1	BT ROOF 2 150 SB	2	BT ROOF 2 150 SBP	3	BT ROOF 2 200 SB	4	BT ROOF 2 200 SBP
5	BT ROOF 2 250 SB	6	BT ROOF 2 250 SBP	7	BT ROOF 2 315 SB	8	BT ROOF 2 315 SBP

## AIR FLOW - PRESSURE

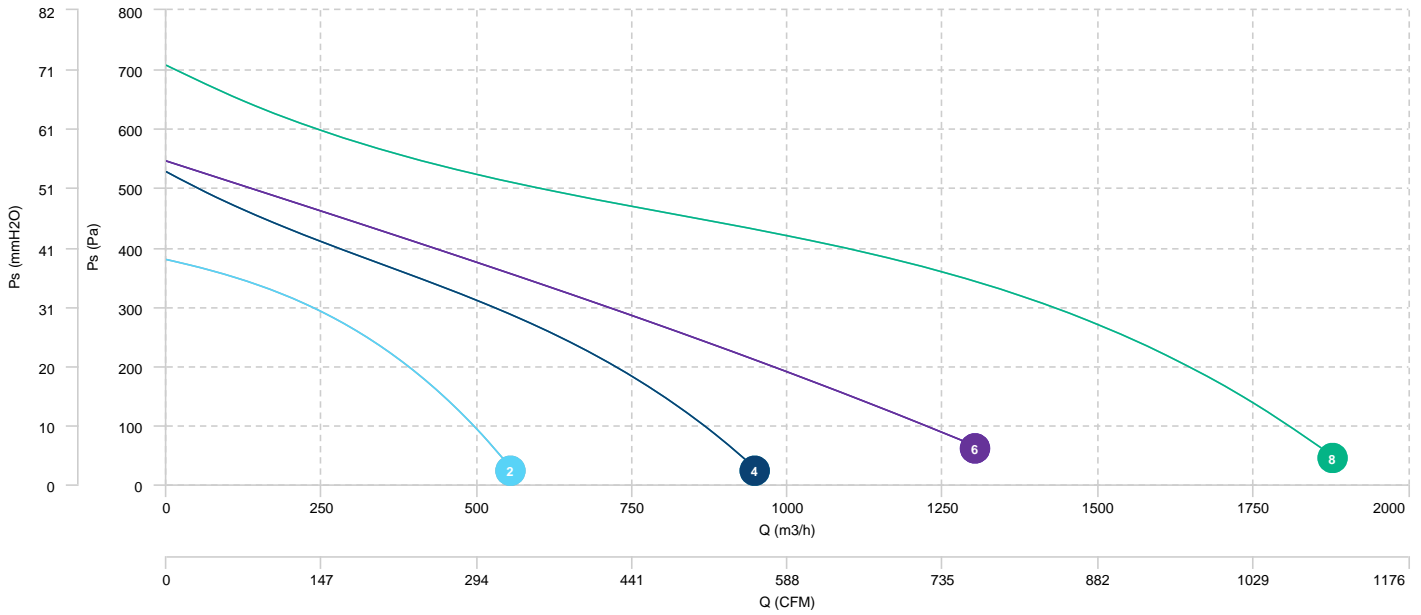

## AIR FLOW - ABSORBED POWER

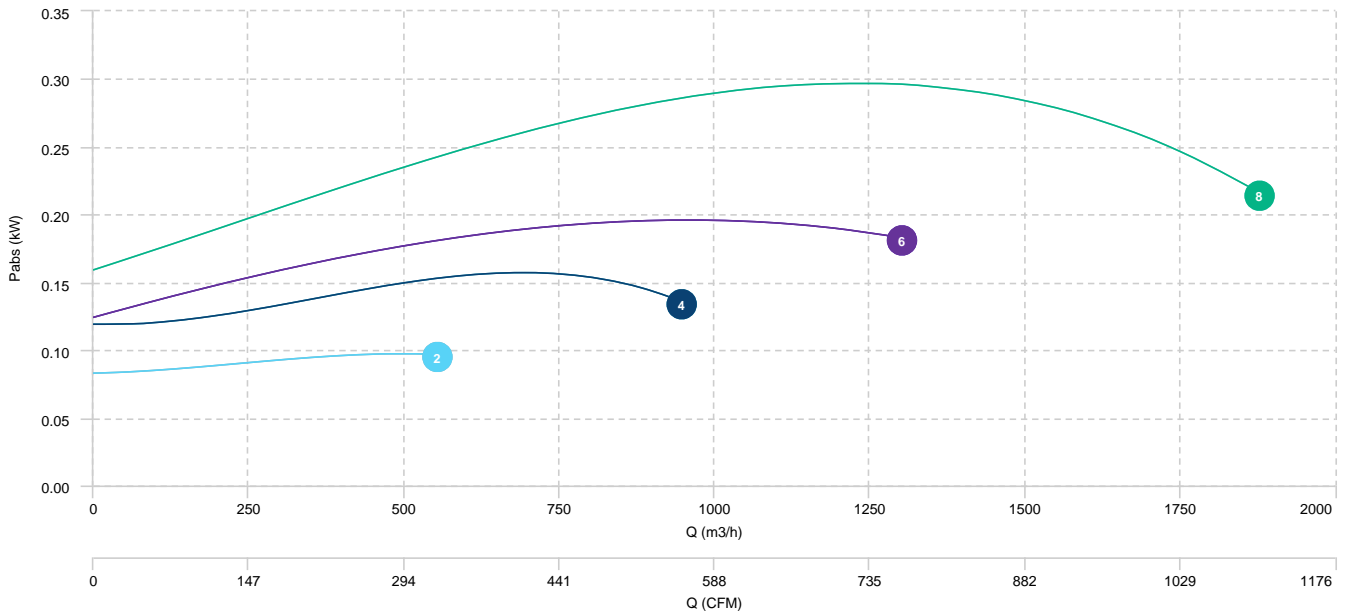

## Sound data

Sound power Lw dB (A)										
Model		63 Hz	125 Hz	250 Hz	500 Hz	1000 Hz	2000 Hz	4000 Hz	8000 Hz	Total
BT ROOF 2 150 SB	Inlet	45	65	64	63	61	60	48	39	71
	Radiated	39	59	55	37	20	17	26	20	64
BT ROOF 2 150 SBP	Inlet	45	65	64	63	61	60	48	39	71
	Radiated	39	59	55	37	20	17	26	20	64
BT ROOF 2 200 SB	Inlet	49	69	67	72	65	61	58	50	77
	Radiated	45	63	61	48	31	25	47	41	64
BT ROOF 2 200 SBP	Inlet	49	69	67	72	65	61	58	50	77
	Radiated	45	63	61	48	31	25	47	41	64
BT ROOF 2 250 SB	Inlet	58	65	66	69	66	62	53	47	74
	Radiated	57	64	60	49	39	39	44	40	65
BT ROOF 2 250 SBP	Inlet	58	65	66	69	66	62	53	47	74
	Radiated	57	64	60	49	39	39	44	40	65
BT ROOF 2 315 SB	Inlet	55	67	68	72	68	66	62	60	77
	Radiated	52	64	63	55	47	52	57	50	68
BT ROOF 2 315 SBP	Inlet	55	67	68	72	68	66	62	60	77
	Radiated	52	64	63	55	47	52	57	50	68

**erp data**

ERP	
Fan type	Unit for non-residential ventilation (LOT 6)
Typology	Unidirectional
Others	None
Type of driver	None

Model	Motor power (kW)	Maximum efficiency point data						
		Eff.Heat recovery (%)	Max. efficiency (%)	Pabs (kW)	Air Flow (m3/h)	Ps (Pa)	Speed (m/s)	SFP (W/m3/s)
BT ROOF 2 200 SB	0,15	-	30,41	0,15	556,30	285,78	4.92	990,75
BT ROOF 2 200 SBP	0,15	-	30,41	0,15	556,30	285,78	4.92	990,75
BT ROOF 2 250 SB	0,19	-	32,44	0,19	680,69	310,09	3.85	997,34
BT ROOF 2 250 SBP	0,19	-	32,44	0,19	680,69	310,09	3.85	997,34