

BOX RLQ PLUS

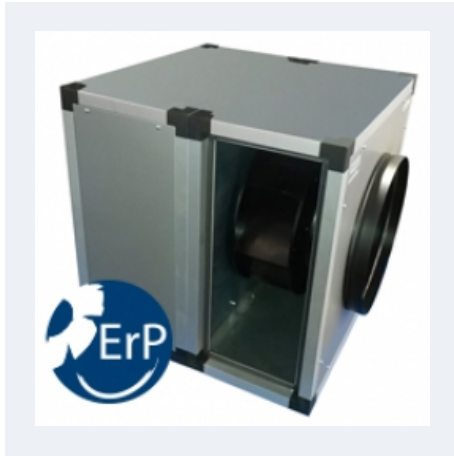

VENTILATION BOX WITH BACKWARD TURBINE

MANUFACTURING FEATURES:

- Casing with profile structure made of aluminium 30 mm.casing, nylon corners, steel sandwich panel with inner rock wool insulation.
- Circular inlets for duct connection.
- High efficiency backward turbine in steel sheet, balanced static and dinamically in origin.
- Standard asynchronous squirrel-cage motor with IP-55 protection and Class F insulation. Standard voltages 230/400V, 50Hz.
- Maximum working temperature 80°C.

APPLICATIONS:

Designed for inline installation, they are suitable for:

- Air renewal in buildings and industries.
- Smoke extraction.

Accessories



FILTRO
EMC



INT



SFC

Technical data

Three-phase motor / 2 poles

Code	Model	R.P.M.	Rated I. (A) 400V	Rated power kW	Max. Airflow m3/h	Sound db (A)*	Weight	Connect. diagram
246310106Q	BOX RLQ PLUS 315 T2 1,1kW	2800	2,33	1,10	4.400	51	64	1
246350106Q	BOX RLQ PLUS 355 T2 2,2kW	2800	4,58	2,20	6.740	54	73	1

Three-phase motor / 4 poles

Code	Model	R.P.M.	Rated I. (A) 400V	Rated power kW	Max. Airflow m3/h	Sound db (A)*	Weight	Connect. diagram
246311106Q	BOX RLQ PLUS 315 T4 0,25kW	1400	0,79	0,25	2.220	46	60	1
246351106Q	BOX RLQ PLUS 355 T4 0,55kW	1400	1,49	0,55	3.400	49	68	1
246400106Q	BOX RLQ PLUS 400 T4 0,75kW	1390	1,63	0,75	5.040	52	84	1
246450106Q	BOX RLQ PLUS 450 T4 1,1kW	1400	2,49	1,10	6.940	56	120	1

Notes:

* Total sound pressure level at the point of maximum flow measured in dB(A) in the suction measured in free field at a distance of 6m from the source

Dimensions

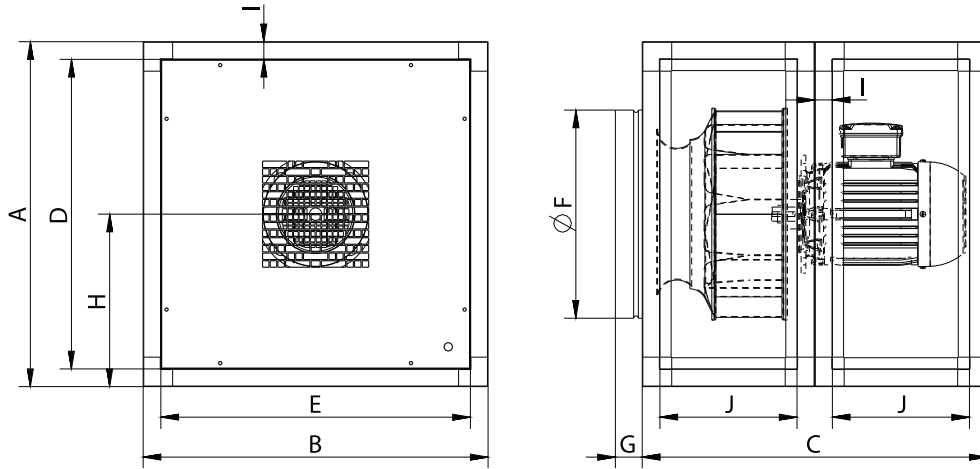

Model	A	B	C	D	E	G	H	I	J
BOX RLQ PLUS 315 T2 1,1kW	525	525	525	465	465	70	262,5	30	174,5
BOX RLQ PLUS 315 T4 0,25kW	525	525	525	465	465	70	262,5	30	174,5
BOX RLQ PLUS 355 T2 2,2kW	585	585	585	525	525	70	292,5	30	232,5
BOX RLQ PLUS 355 T4 0,55kW	585	585	585	525	525	70	292,5	30	232,5
BOX RLQ PLUS 400 T4 0,75kW	650	650	650	590	590	70	325	30	265
BOX RLQ PLUS 450 T4 1,1kW	725	725	725	665	665	70	362,5	30	302,5

Model	ØF
BOX RLQ PLUS 315 T2 1,1kW	298
BOX RLQ PLUS 315 T4 0,25kW	298
BOX RLQ PLUS 355 T2 2,2kW	353
BOX RLQ PLUS 355 T4 0,55kW	353
BOX RLQ PLUS 400 T4 0,75kW	398
BOX RLQ PLUS 450 T4 1,1kW	448

Wiring diagram

DIAGRAM Nº 1

230/400V

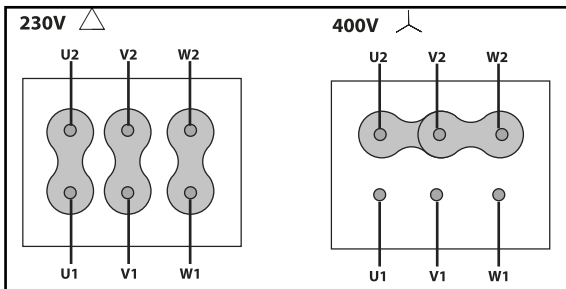

400/690V

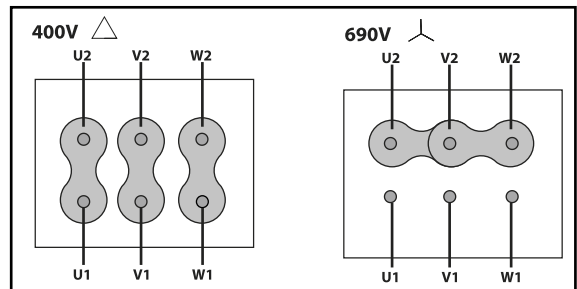

CHARACTERISCTIC CURVE

1 BOX RLQ PLUS 315 T2 1, 1kW

2 BOX RLQ PLUS 355 T2 2, 2kW

AIR FLOW - PRESSURE

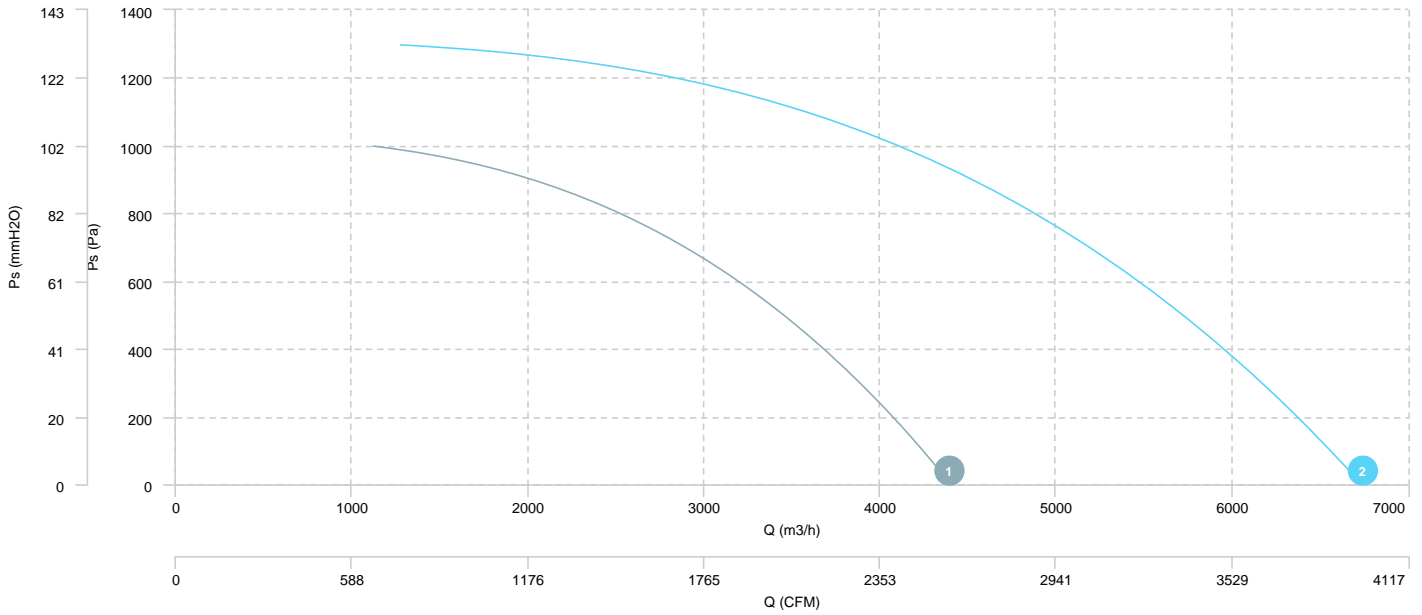

AIR FLOW - ABSORBED POWER

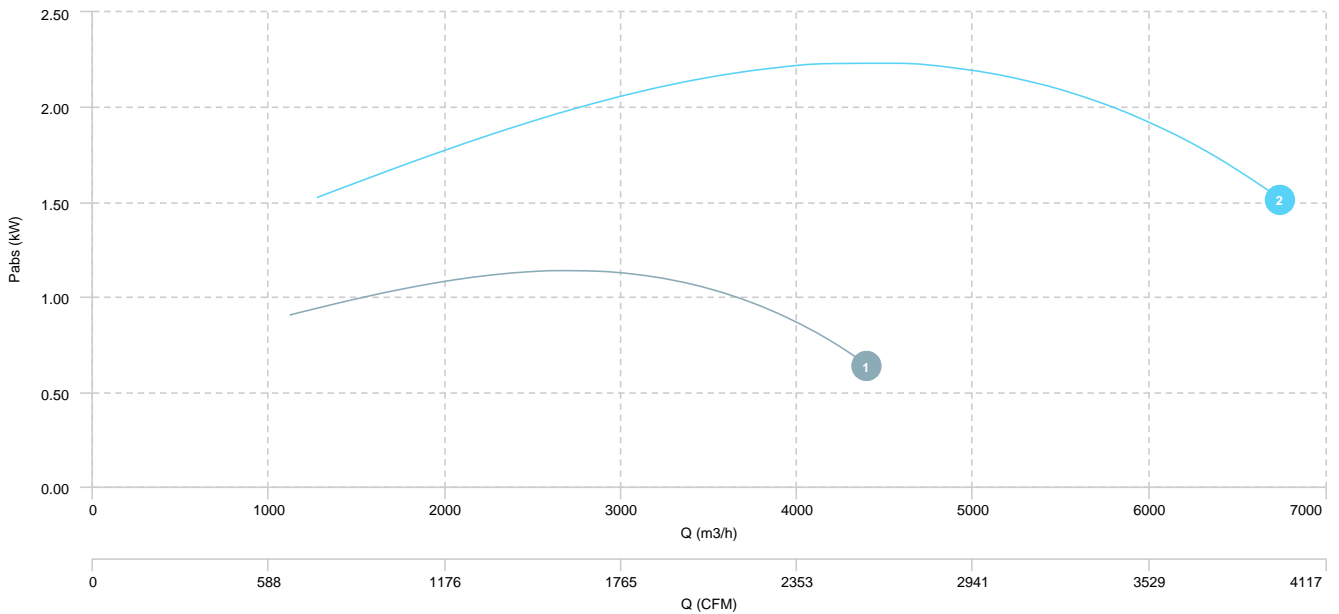

- 1 BOX RLQ PLUS 315 T4 0, 25kW
- 2 BOX RLQ PLUS 355 T4 0, 55kW
- 3 BOX RLQ PLUS 400 T4 0, 75kW
- 4 BOX RLQ PLUS 450 T4 1, 1kW

AIR FLOW - PRESSURE

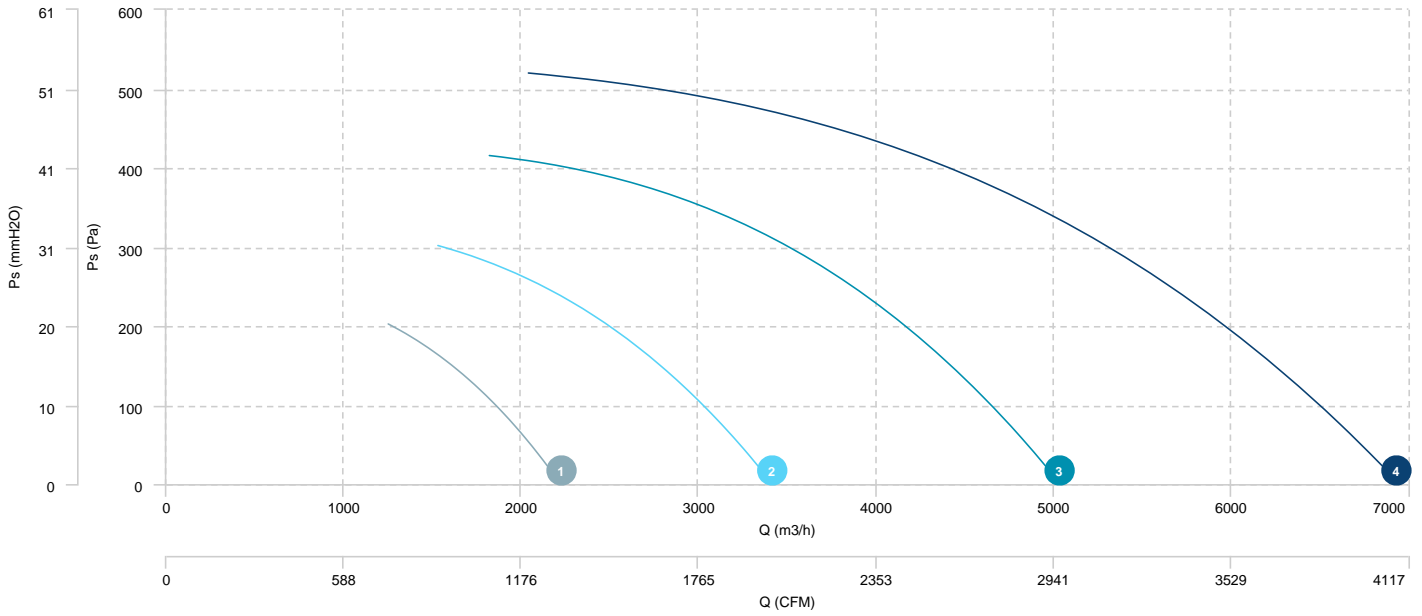

AIR FLOW - ABSORBED POWER

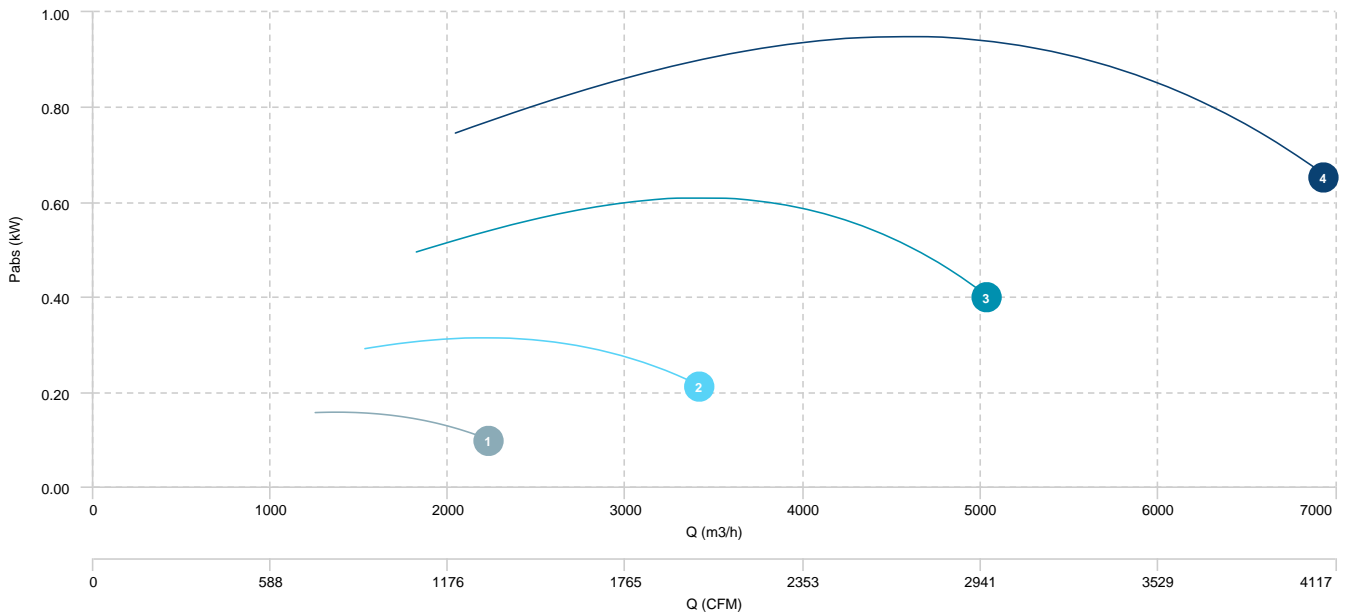

Sound data

Sound / 2 poles

Sound power Lw dB (A)										
Model		63 Hz	125 Hz	250 Hz	500 Hz	1000 Hz	2000 Hz	4000 Hz	8000 Hz	Total
BOX RLQ PLUS 315 T2 1,1kW	Inlet	50	69	70	68	69	70	68	54	77
BOX RLQ PLUS 355 T2 2,2kW	Inlet	53	72	73	71	72	73	71	57	80

Sound / 4 poles

Sound power Lw dB (A)										
Model		63 Hz	125 Hz	250 Hz	500 Hz	1000 Hz	2000 Hz	4000 Hz	8000 Hz	Total
BOX RLQ PLUS 315 T4 0,25kW	Inlet	45	64	65	63	64	65	63	49	72
BOX RLQ PLUS 355 T4 0,55kW	Inlet	48	67	68	66	67	68	66	52	75
BOX RLQ PLUS 400 T4 0,75kW	Inlet	51	70	71	69	70	71	69	55	78
BOX RLQ PLUS 450 T4 1,1kW	Inlet	55	74	75	73	74	74	73	59	82

erp data

ERP	
Fan type	Unit for non-residential ventilation (LOT 6)
Typology	Unidirectional
Others	None
Type of driver	None

ERP / 2 poles

Model	Motor power (kW)	Maximum efficiency point data						
		Eff.Heat recovery (%)	Max. efficiency (%)	Pabs (kW)	Air Flow (m3/h)	Ps (Pa)	Speed (m/s)	SFP (W/m3/s)
BOX RLQ PLUS 315 T2 1,1kW	1,1	-	53,90	1,14	2.780,16	732,49	9.91	1.473,09
BOX RLQ PLUS 355 T2 2,2kW	2,2	-	54,85	2,23	4.094,03	1.001,50	11.49	1.956,29

ERP / 4 poles

Model	Motor power (kW)	Maximum efficiency point data						
		Eff.Heat recovery (%)	Max. efficiency (%)	Pabs (kW)	Air Flow (m3/h)	Ps (Pa)	Speed (m/s)	SFP (W/m3/s)
BOX RLQ PLUS 315 T4 0,25kW	0,25	-	49,24	0,16	1.397,01	183,91	4.98	403,20
BOX RLQ PLUS 355 T4 0,55kW	0,55	-	50,44	0,31	2.075,92	255,49	5.83	541,76
BOX RLQ PLUS 400 T4 0,75kW	0,75	-	53,05	0,60	3.046,42	349,22	6.73	709,61
BOX RLQ PLUS 450 T4 1,1kW	1,1	-	55,52	0,95	4.259,02	413,57	7.44	798,71