

BOX RL



BACKWARD CENTRIFUGAL IN SOUNDPROOF

MANUFACTURING FEATURES

- Box manufactured in galvanised steel sheet.
- Backward impeller with self-cleaning system, direct coupling motor.
- Standard asynchronous squirrel-cage motor with IP-55 protection and Class F insulation.
- Manufactured with standard voltages: 230/400V 50Hz in three phase motors up to 4kW, and 400/690V 50Hz for higher powers.
- Exchangeable pannels.
- Open outlet.

APPLICATIONS

Designed for inline installation, they are suitable for:

- Air renewal in buildings and industries.
- Maximum working temperature: 60°C.

Accessories



BA-400



CPM



FILTRO
EMC



INT



JE 45



SFC



SIL-C /
SIL-CN



TIAC

UNDER REQUEST

- Special voltages.
- Double skin insulation.

Technical data

Three-phase motor / 4 poles

Code	Model	R.P.M.	Rated I. (A) 400V	Rated power kW	Max. Airflow m3/h	Sound db (A)**	Weight	Connect. diagram
241390106	BOX RL 400 T4 0,75kW	1390	1,63	0,75	4.960	50	110	1
241460106	BOX RL 450 T4 1,1kW	1400	2,49	1,10	6.580	55	137	1
241520106	BOX RL 500 T4 1,5kW	1400	3,26	1,50	8.390	60	142	1
241600106	BOX RL 560 T4 2,2kW	1430	4,64	2,20	12.850	62	182	1
241670106	BOX RL 630 T4 5,5kW	1440	10,5	5,50	19.180	66	213	1
241770106	BOX RL 710 T4 7,5kW	1440	14,1	7,50	21.350	75	268	1
241830106	BOX RL 800 T4 15kW	1460	29,8	15	32.250	83	334	1

Three-phase motor / 6 poles

Code	Model	R.P.M.	Rated I. (A) 400V	Rated power kW	Max. Airflow m3/h	Sound db (A)**	Weight	Connect. diagram
241440106	BOX RL 400 T6 0,55kW	900	1,8	0,55	2.770	40	110	1
241470106	BOX RL 450 T6 0,55kW	900	1,8	0,55	4.370	45	136	1
241540106	BOX RL 500 T6 0,55kW	900	1,8	0,55	5.590	50	141	1
241620106	BOX RL 560 T6 0,75kW	910	1,95	0,75	8.130	52	171	1
241660106	BOX RL 630 T6 1,5kW	940	3,71	1,50	12.710	56	193	1
241760106	BOX RL 710 T6 2,2kW	940	5,94	2,20	16.560	65	258	1
241840106	BOX RL 800 T6 4kW	960	9,46	4	20.950	73	334	1

2 SPEED MOTOR / 4/8 poles

Code	Model	R.P.M.	Rated I. (A) 400V	Rated power kW	Max. Airflow m3/h	Sound db (A)**	Weight	Connect. diagram
2415201062V	BOX RL 500 T4/T8 1,5/0,3kW	1400	4/1,5	1,5/ 0,3	8.400	60	142	2
2416001062V	BOX RL 560 T4/T8 2,2/0,45kW	1430	4/1,25	2,2/ 0,45	12.850	62	182	2
2416701062V	BOX RL 630 T4/T8 5,5/1,1kW	1440	11/27,2	5,5/ 1,1	19.190	66	193	2
2417701062V	BOX RL 710 T4/T8 7,5/1,5kW	1440	15/4	7,5/ 1,5	21.350	75	268	2

Notes:

** Total sound pressure level at the point of maximum flow measured in dB(A) in the suction measured in free field at a distance of 6m from the source

Dimensions

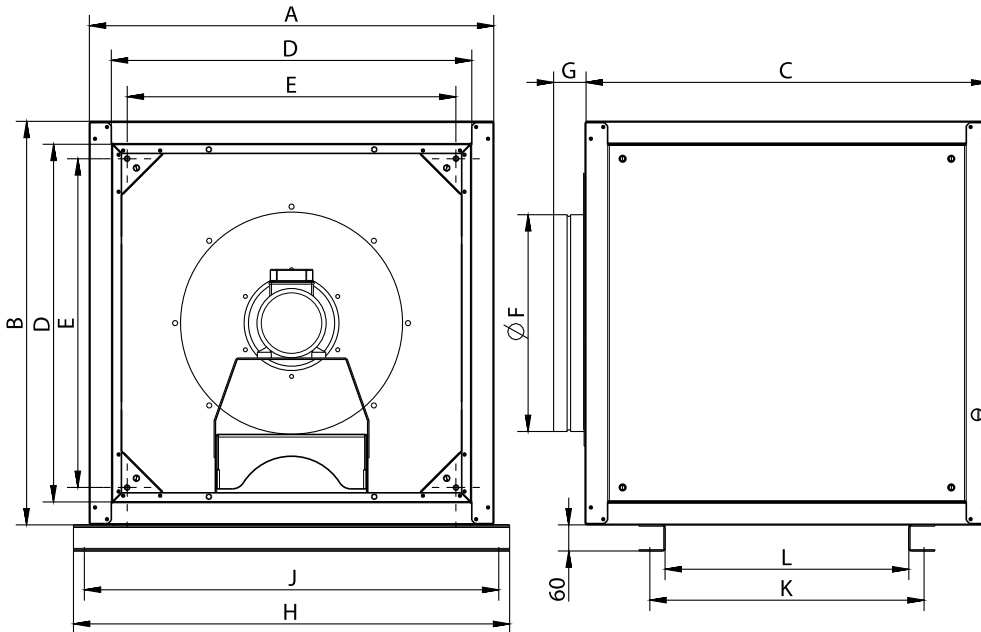

Model	A	B	C	D	E	G	H	J	K
BOX RL 400 T4 0,75kW	800	800	800	696	628,5	74	1002	952	628,5
BOX RL 400 T6 0,55kW	800	800	800	696	628,5	74	1002	952	628,5
BOX RL 450 T4 1,1kW	800	800	800	696	628,5	74	1002	952	628,5
BOX RL 450 T6 0,55kW	800	800	800	696	628,5	74	1002	952	628,5
BOX RL 500 T4 1,5kW	925	925	925	821	753	74	1127	1077	753
BOX RL 500 T6 0,55kW	925	925	925	821	753	74	1127	1077	753
BOX RL 500 T4/T8 1,5/0,3kW	925	925	925	821	753	74	1127	1077	753
BOX RL 560 T4 2,2kW	925	925	925	821	753	74	1127	1077	753
BOX RL 560 T6 0,75kW	925	925	925	821	753	74	1127	1077	753
BOX RL 560 T4/T8 2,2/0,45kW	925	925	925	821	753	74	1127	1077	753
BOX RL 630 T4 5,5kW	1000	1000	1000	892	828	74	1203	1153	828
BOX RL 630 T6 1,5kW	1000	1000	1000	892	828	74	1203	1153	828
BOX RL 630 T4/T8 5,5/1,1kW	1000	1000	1000	892	828	74	1203	1153	828
BOX RL 710 T4 7,5kW	1000	1000	1000	892	828	74	1203	1153	828
BOX RL 710 T6 2,2kW	1000	1000	1000	892	828	74	1203	1153	828
BOX RL 710 T4/T8 7,5/1,5kW	1000	1000	1000	892	828	74	1203	1153	828
BOX RL 800 T4 15kW	1060	1060	1060	952	887	74	1262	1212	887
BOX RL 800 T6 4kW	1060	1060	1060	952	887	74	1262	1212	887

Model	L	ØF
BOX RL 400 T4 0,75kW	558,5	398
BOX RL 400 T6 0,55kW	558,5	398

Model	L	ØF
BOX RL 450 T4 1,1kW	558,5	448
BOX RL 450 T6 0,55kW	558,5	448
BOX RL 500 T4 1,5kW	683	498
BOX RL 500 T6 0,55kW	683	498
BOX RL 500 T4/T8 1,5/0,3kW	683	498
BOX RL 560 T4 2,2kW	683	548
BOX RL 560 T6 0,75kW	683	548
BOX RL 560 T4/T8 2,2/0,45kW	683	548
BOX RL 630 T4 5,5kW	758	628
BOX RL 630 T6 1,5kW	758	628
BOX RL 630 T4/T8 5,5/1,1kW	758	628
BOX RL 710 T4 7,5kW	758	698
BOX RL 710 T6 2,2kW	758	698
BOX RL 710 T4/T8 7,5/1,5kW	758	698
BOX RL 800 T4 15kW	817	798
BOX RL 800 T6 4kW	817	798

Wiring diagram

DIAGRAM Nº 1

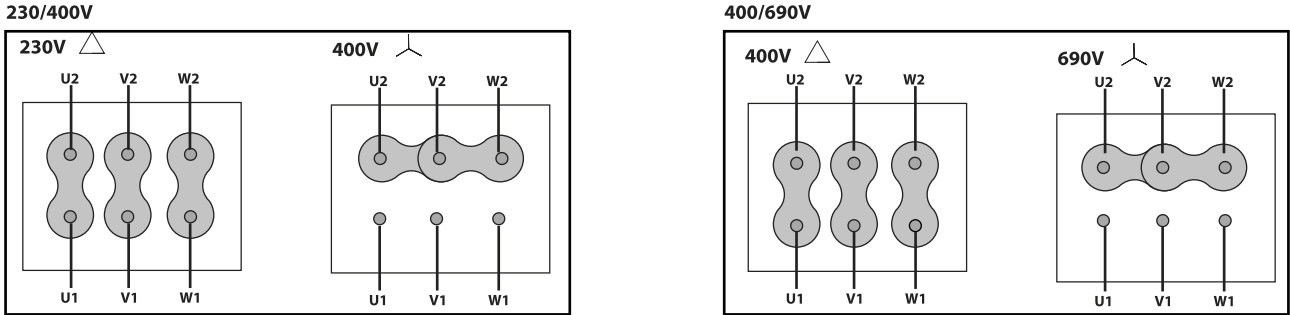
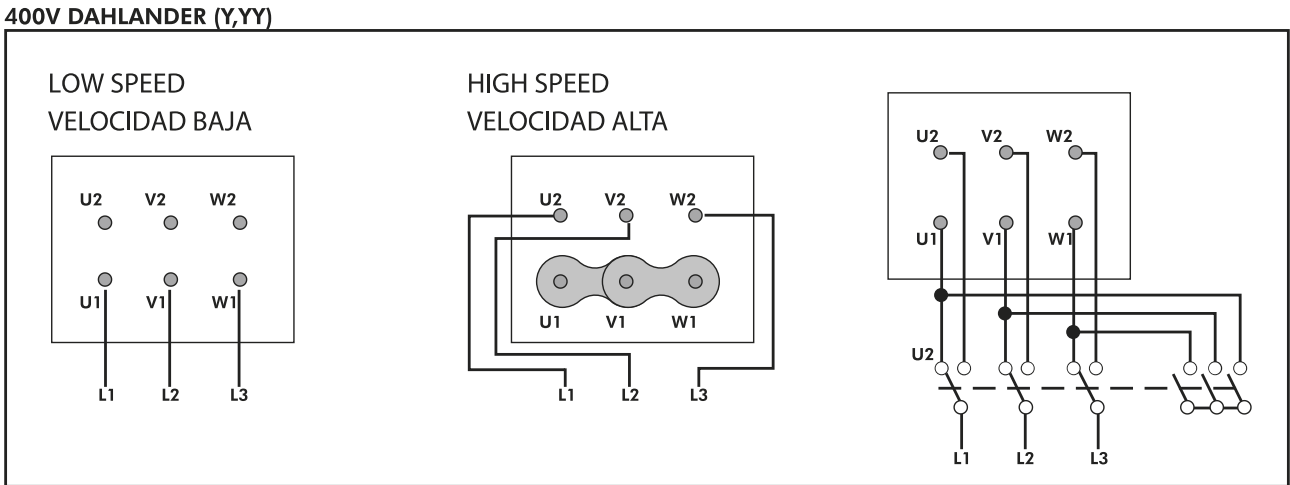

DIAGRAM Nº 2



CHARACTERISCTIC CURVE

1	BOX RL 400 T4 0,75kW	2	BOX RL 450 T4 1,1kW	3	BOX RL 500 T4 1,5kW	4	BOX RL 560 T4 2,2kW
5	BOX RL 630 T4 5,5kW	6	BOX RL 710 T4 7,5kW	7	BOX RL 800 T4 15kW		

AIR FLOW - PRESSURE

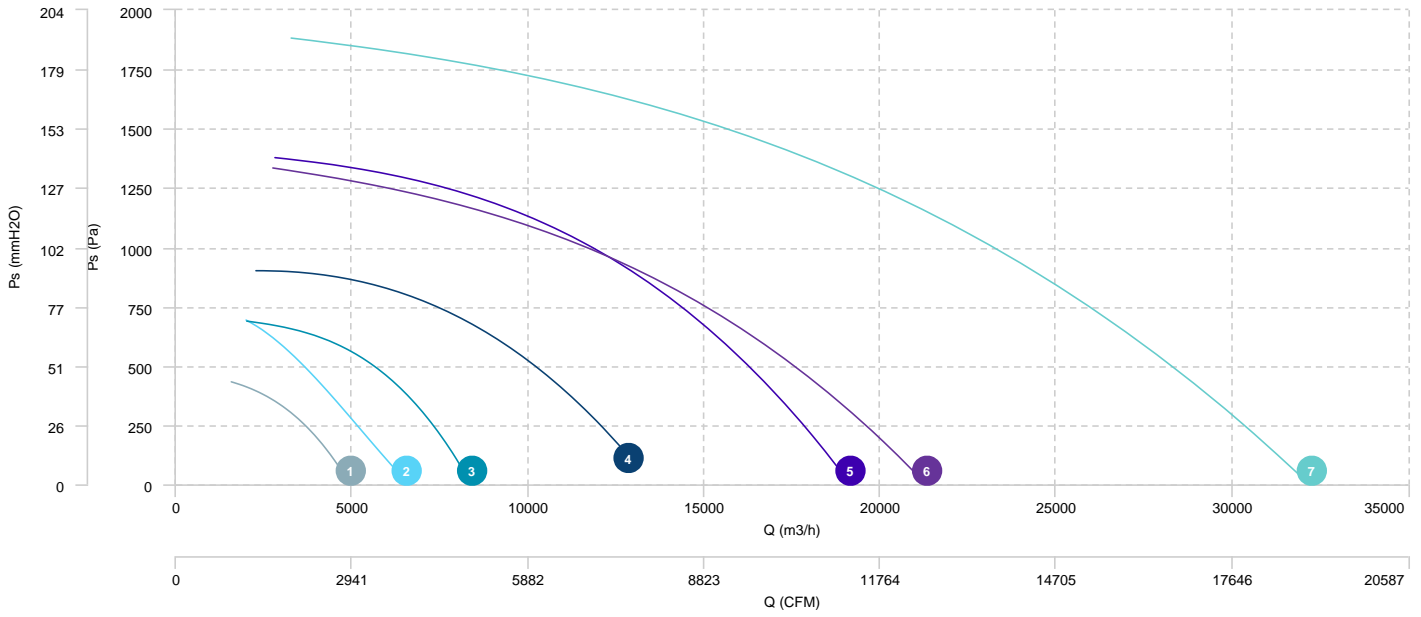

1	BOX RL 400 T6 0,55kW	2	BOX RL 450 T6 0,55kW	3	BOX RL 500 T6 0,55kW	4	BOX RL 560 T6 0,75kW
5	BOX RL 630 T6 1,5kW	6	BOX RL 710 T6 2,2kW	7	BOX RL 800 T6 4kW		

AIR FLOW - PRESSURE

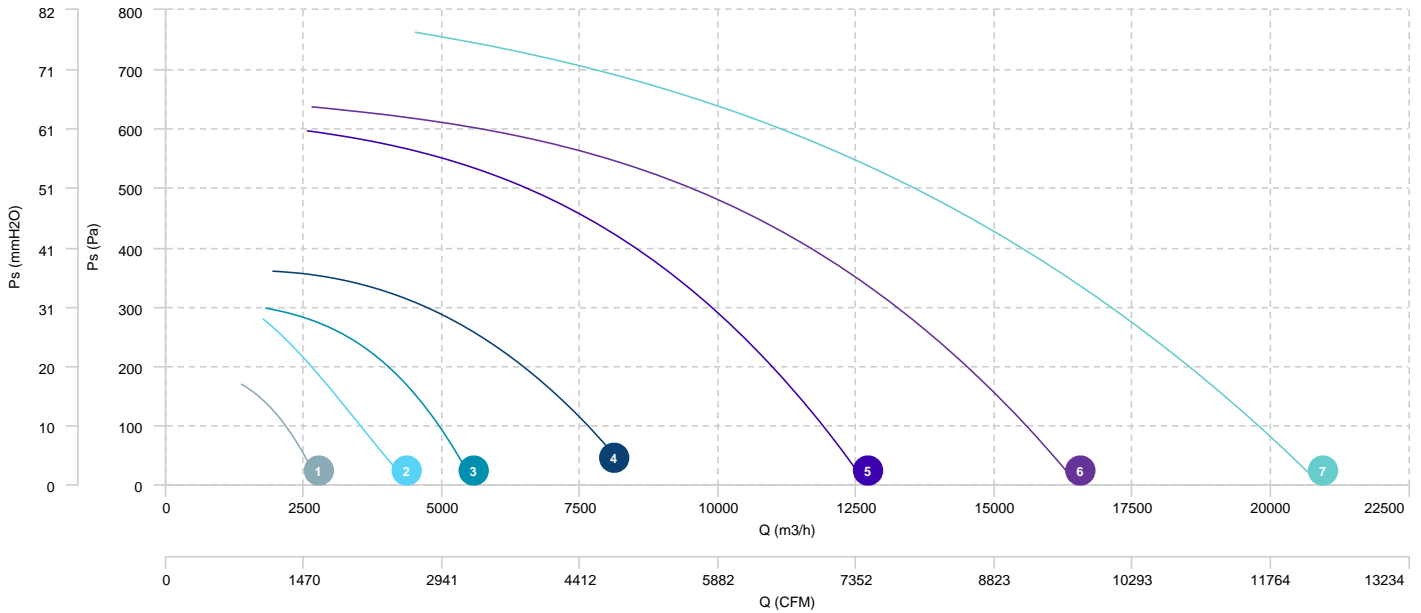

- | | | | | | | | |
|---|--------------------------------|---|---------------------------------|---|--------------------------------|---|--------------------------------|
| 1 | BOX RL 500 T4/T8 1,5/0,
3kW | 2 | BOX RL 560 T4/T8 2,2/0,
45kW | 3 | BOX RL 630 T4/T8 5,5/1,
1kW | 4 | BOX RL 710 T4/T8 7,5/1,
5kW |
|---|--------------------------------|---|---------------------------------|---|--------------------------------|---|--------------------------------|

AIR FLOW - PRESSURE (4 poles)

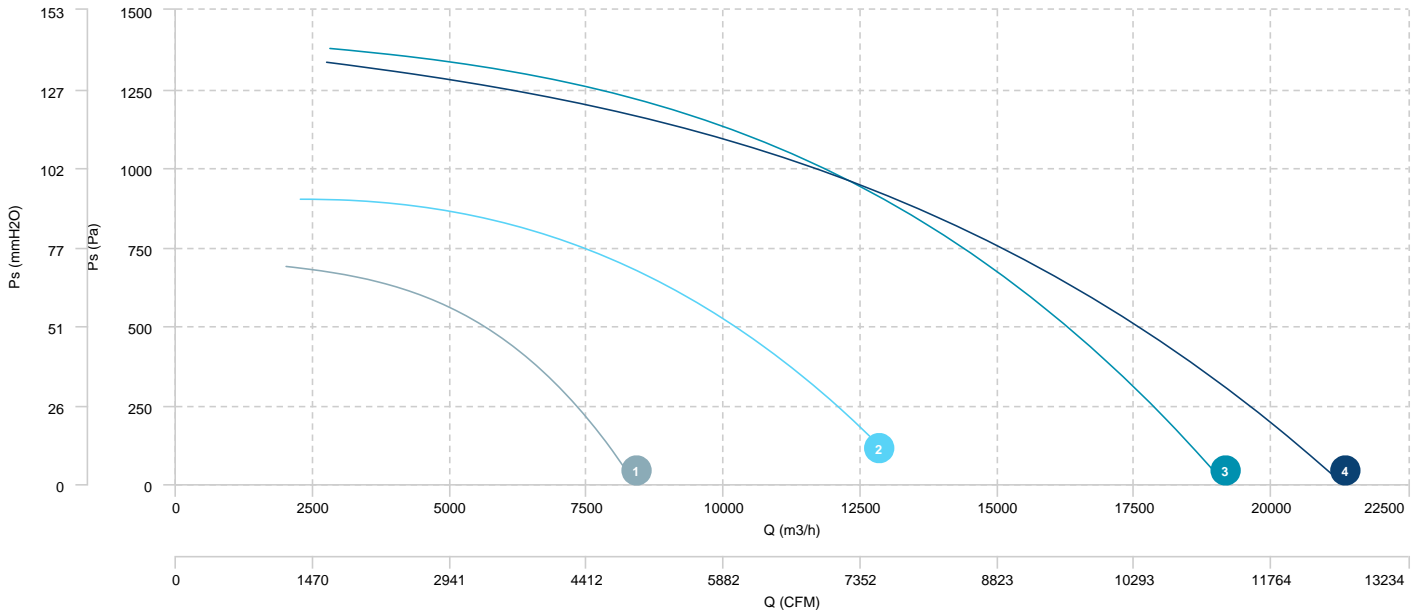

- | | | | | | | | |
|---|--------------------------------|---|---------------------------------|---|--------------------------------|---|--------------------------------|
| 1 | BOX RL 500 T4/T8 1,5/0,
3kW | 2 | BOX RL 560 T4/T8 2,2/0,
45kW | 3 | BOX RL 630 T4/T8 5,5/1,
1kW | 4 | BOX RL 710 T4/T8 7,5/1,
5kW |
|---|--------------------------------|---|---------------------------------|---|--------------------------------|---|--------------------------------|

AIR FLOW - PRESSURE (8 poles)

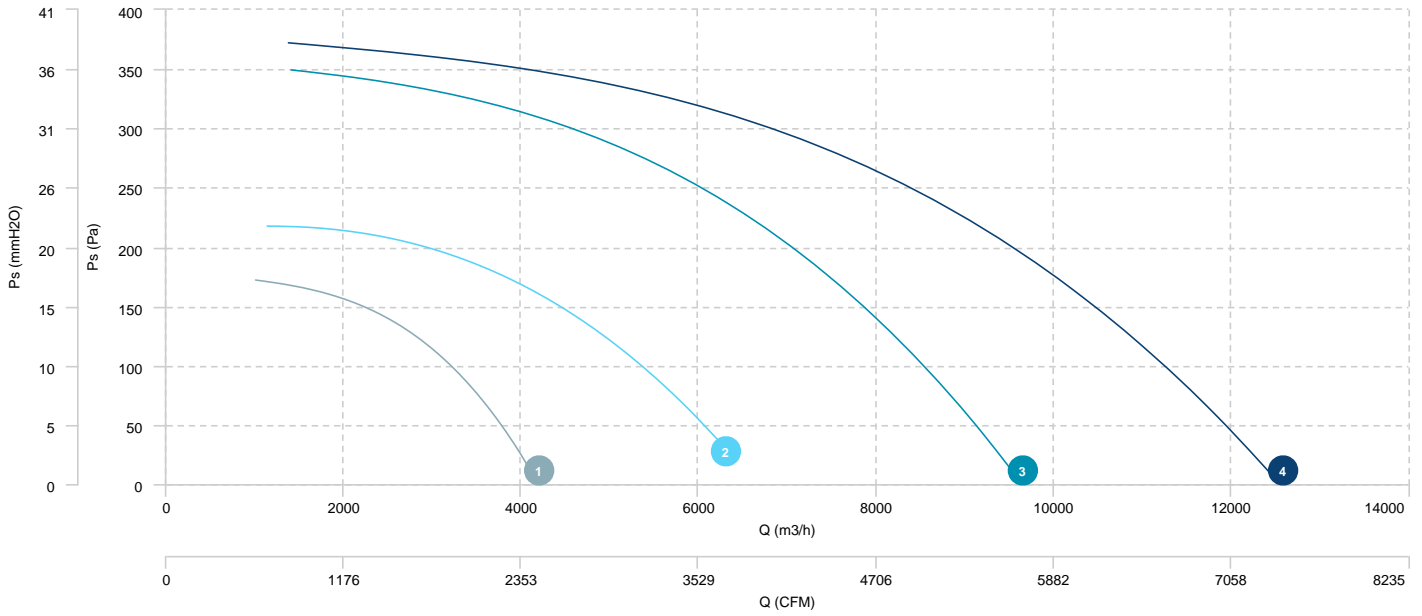

Sound data

Sound / 4 poles

Sound power Lw dB (A)										
Model		63 Hz	125 Hz	250 Hz	500 Hz	1000 Hz	2000 Hz	4000 Hz	8000 Hz	Total
BOX RL 400 T4 0,75kW	Inlet	47	61	67	70	70	71	61	50	76
BOX RL 450 T4 1,1kW	Inlet	56	66	72	74	75	75	67	59	81
BOX RL 500 T4 1,5kW (1400 RPM)	Inlet	66	72	77	78	81	80	73	68	86
BOX RL 560 T4 2,2kW (1430 RPM)	Inlet	72	77	76	74	86	75	66	60	88
BOX RL 630 T4 5,5kW (1440 RPM)	Inlet	74	79	85	87	85	82	75	67	92
BOX RL 710 T4 7,5kW (1440 RPM)	Inlet	80	81	89	92	95	96	92	78	101
BOX RL 800 T4 15kW	Inlet	88	94	99	100	104	103	96	89	109

Sound / 6 poles

Sound power Lw dB (A)										
Model		63 Hz	125 Hz	250 Hz	500 Hz	1000 Hz	2000 Hz	4000 Hz	8000 Hz	Total
BOX RL 400 T6 0,55kW	Inlet	37	51	57	60	60	61	51	40	66
BOX RL 450 T6 0,55kW	Inlet	46	56	62	64	65	65	57	49	71
BOX RL 500 T6 0,55kW	Inlet	56	62	67	68	71	70	63	58	76
BOX RL 560 T6 0,75kW	Inlet	57	63	69	69	73	73	65	58	78
BOX RL 630 T6 1,5kW	Inlet	70	73	72	76	78	63	60	60	82
BOX RL 710 T6 2,2kW	Inlet	80	83	82	85	87	72	69	63	91
BOX RL 800 T6 4kW	Inlet	85	90	90	92	96	80	77	72	99

Sound / 4/8 poles

Sound power Lw dB (A)										
Model		63 Hz	125 Hz	250 Hz	500 Hz	1000 Hz	2000 Hz	4000 Hz	8000 Hz	Total
BOX RL 500 T4/T8 1,5/0,3kW (1400 RPM)	Inlet	66	72	77	78	81	80	73	68	86
BOX RL 560 T4/T8 2,2/0,45kW (1430 RPM)	Inlet	72	77	76	74	86	75	66	60	88
BOX RL 630 T4/T8 5,5/1,1kW (1440 RPM)	Inlet	74	79	85	87	85	82	75	67	92
BOX RL 710 T4/T8 7,5/1,5kW (1440 RPM)	Inlet	80	81	89	92	95	96	92	78	101

Notes:

* To calculate the sound power level at different rpm from those indicated above, use the following formula:

$$Lw \text{ dB(A)}_{rpmA} = Lw \text{ dB(A)}_{rpmB} + 52.5 \cdot \log_{10} \frac{rpmA}{rpmB}$$

