

AA P/R

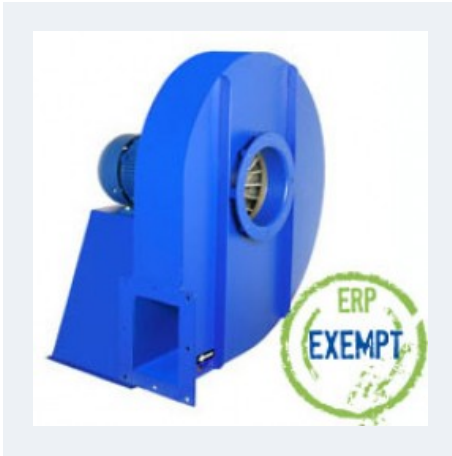

HIGH PRESSURE WITH STRAIGHT IMPELLER

MANUFACTURING FEATURES:

- Rolling steel sheet housing.
- Fully welded housing.
- Straight blade impeller manufactured of rolled steel sheet and polyester powder finishing coat.
- Polyester powder finishing coat.
- Standard asynchronous squirrel-cage motor with IP-55 protection and class F insulation. Manufactured with standard voltages: 230V 50Hz in single phase motors and 230/400V 50Hz in three phase motors up to 4kW and 400/690V 50Hz for higher powers.
- Standard orientation LG270

Accessories



APPLICATIONS:

- Designed for inline installation, they are suitable for:
- Solid material transport (except for textile fibers).
 - Maximum working temperature: carried air: 130°C, ambient: 60°C.

UNDER REQUEST:

- 60Hz fans and special voltages.
- 2 speed motors.
- Hot-dipped galvanised or stainless steel fan.
- Orientation: LG0, LG45, LG90, LG135, LG180, LG225, LG315.

Technical data

Three-phase motor

Code	Model	R.P.M.	Rated I. (A) 400V	Rated power kW	Max. Airflow m3/h	Sound db (A)**	Weight	Connect. diagram
255120160	AA 45/5 T2 2,2kW P/R	2800	4,58	2,20	2.900	79	68	1
255120161	AA 45/5 T2 3kW P/R	2870	5,92	3	3.100	79	69	1
255150160	AA 50/5 T2 4kW P/R	2890	7,63	4	3.100	83	119	1
255150161	AA 50/5 T2 5,5kW P/R	2900	10,6	5,50	4.000	83	120	1
255520161	AA 60/7 T2 7,5kW P/R	2900	14,1	7,50	4.200	85	177	1
255520160	AA 60/7 T2 11kW P/R	2930	20,8	11	5.000	85	177	1

Notes:

** Total sound pressure level at the point of maximum flow measured in dB(A) in the suction measured in free field at a distance of 6m from the source

Dimensions

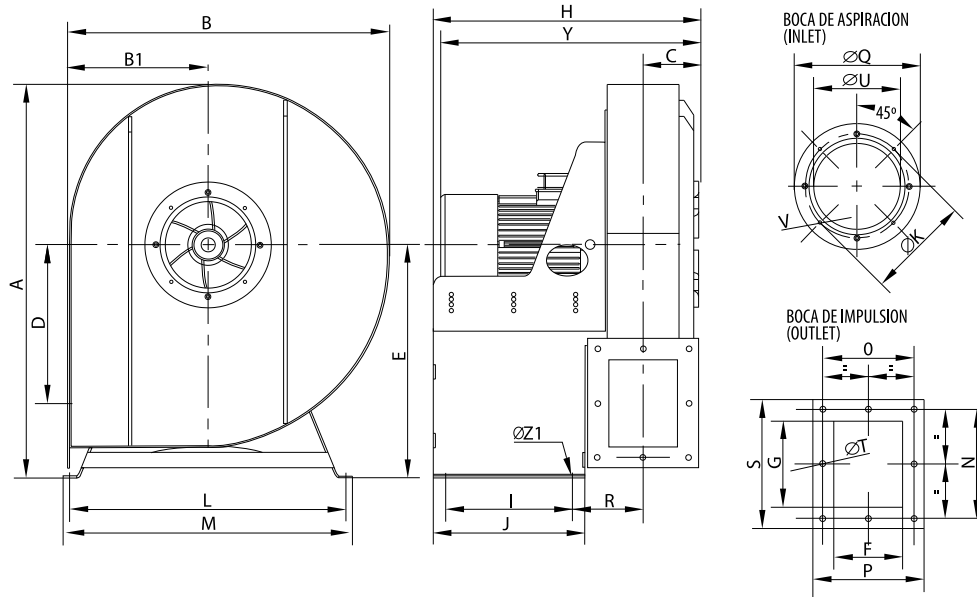

Model	A	B	B1	C	D	E	F	G	H
AA 45/5 T2 2,2kW P/R	776	635	276,5	115	313	460	135	170	529,5
AA 45/5 T2 3kW P/R	776	635	276,5	115	313	460	135	170	529,5
AA 50/5 T2 4kW P/R	877	716,5	307,25	121	358	520	150	200	583
AA 50/5 T2 5,5kW P/R	877	716,5	307,25	121	358	520	150	200	583
AA 60/7 T2 7,5kW P/R	922,5	777,5	347,75	132,5	383	535	170	170	640
AA 60/7 T2 11kW P/R	922,5	777,5	347,75	132,5	383	535	170	170	640

Model	I	J	KØ	L	M	N	O	P	Q
AA 45/5 T2 2,2kW P/R	250	300	205	545	570	215	180	219	249
AA 45/5 T2 3kW P/R	250	300	205	545	570	215	180	219	249
AA 50/5 T2 4kW P/R	275	325	258	589	614	256	206	246	292
AA 50/5 T2 5,5kW P/R	275	325	258	589	614	256	206	246	292
AA 60/7 T2 7,5kW P/R	315	365	280	589	614	226	226	266	325
AA 60/7 T2 11kW P/R	315	365	280	589	614	226	226	266	325

Model	R	S	TØ	UØ	VØ	Y	Z1Ø
AA 45/5 T2 2,2kW P/R	139,5	254	11	170	M6	504,5	11
AA 45/5 T2 3kW P/R	139,5	254	11	170	M6	514,5	11
AA 50/5 T2 4kW P/R	162	280	11	210	M6	548	11
AA 50/5 T2 5,5kW P/R	162	280	11	210	M6	603	11
AA 60/7 T2 7,5kW P/R	168	266	11	246	M6	760,5	11
AA 60/7 T2 11kW P/R	168	266	11	246	M6	625,5	11

Wiring diagram

DIAGRAM Nº 1

230/400V

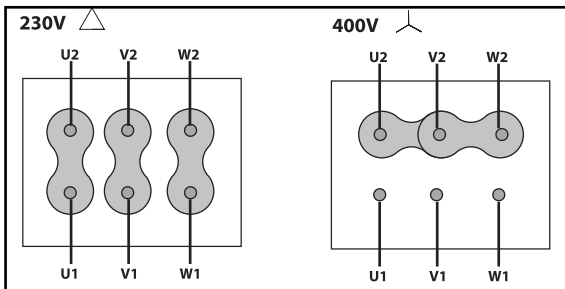

400/690V

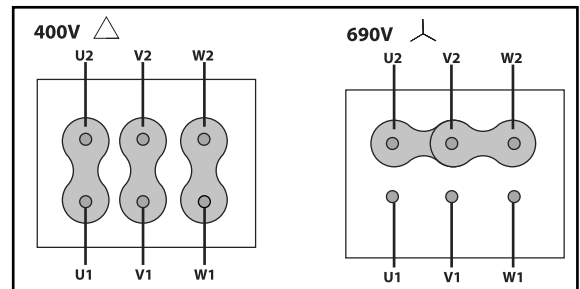

CHARACTERISTIC CURVE

1	AA 45/5 T2 2,2kW P/R	2	AA 45/5 T2 3kW P/R	3	AA 50/5 T2 4kW P/R	4	AA 50/5 T2 5,5kW P/R
5	AA 60/7 T2 7,5kW P/R	6	AA 60/7 T2 11kW P/R				

AIR FLOW - PRESSURE

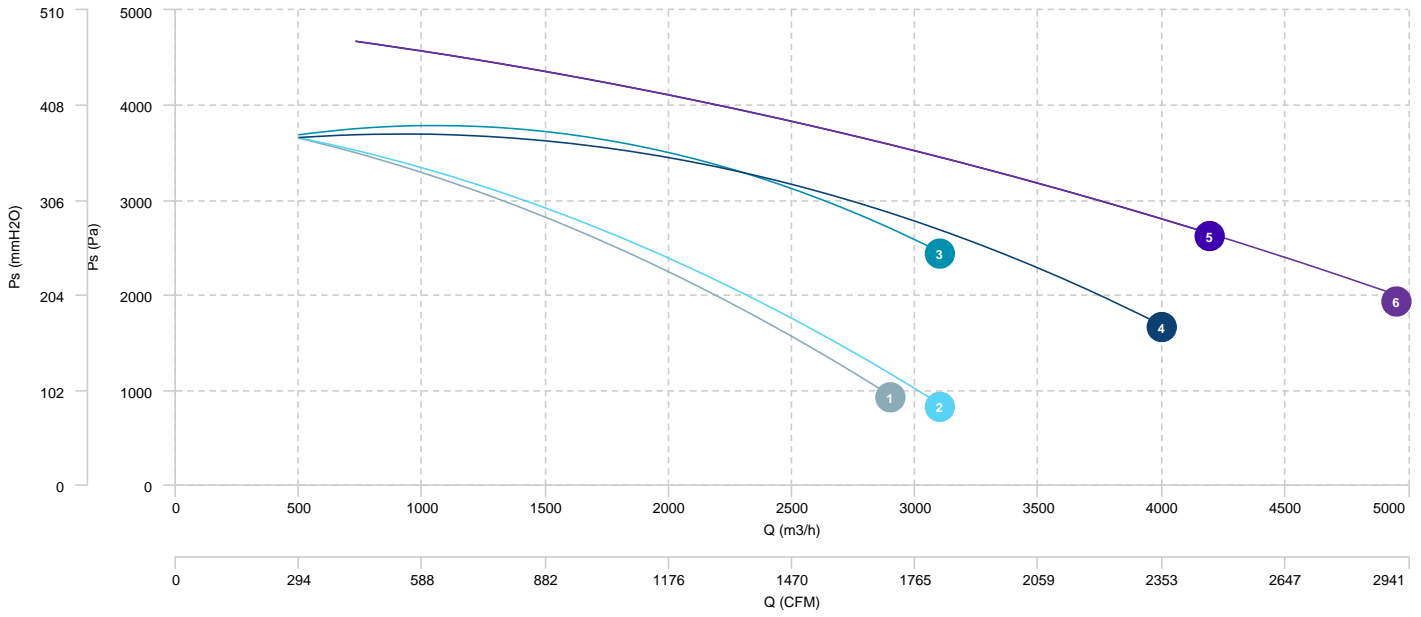

Sound data

Sound power Lw dB (A)										
Model		63 Hz	125 Hz	250 Hz	500 Hz	1000 Hz	2000 Hz	4000 Hz	8000 Hz	Total
AA 45/5 T2 2,2kW P/R	Inlet	68	83	91	99	100	99	91	92	105
AA 45/5 T2 3kW P/R	Inlet	69	83	92	100	100	100	91	92	105
AA 50/5 T2 4kW P/R	Inlet	71	85	94	103	104	103	95	96	109
AA 50/5 T2 5,5kW P/R	Inlet	71	86	95	103	105	103	96	96	109
AA 60/7 T2 7,5kW P/R	Inlet	72	88	97	104	107	104	98	97	111
AA 60/7 T2 11kW P/R	Inlet	72	88	97	104	107	104	98	97	111