Design point

Flow	Q	2880	m ³ /h
Pressure	Δp	383	Pa
Ambient temperature	t _{MED}	20	°C

Duty point

Flow	Q	2881	2880	m ³ /h
Static pressure	Δp _{ST}	383	383	Pa
Dynamic pressure	Δp _D	15	15	Pa
Total pressure	Δp _{TOT}	398	398	Pa
Absorbed power	P _{ABS}	991	991	W
Current	I _{ABS}	4.35	4.35	A
Speed	n	1145	1145	rpm
Speed	v	5.03	5.03	m/s
Static efficiency	η _{ST}	30.9	30.9	%
Total efficiency	η _{TOT}	32.2	32.1	%
SFP	SFP	1239	1239	W/m ³ /s
Regulation		-	-	V

Sound power level	63Hz	125Hz	250Hz	500Hz	1kHz	2kHz	4kHz	8kHz	Σ
Inlet - L _{WA5}	46	58	55	58	57	53	45	35	64
Outlet - L _{WA6}	72	82	76	80	79	76	68	58	86
Edited - L _{WA2}	53	41	54	71	70	69	63	51	75

Sound pressure level	63Hz	125Hz	250Hz	500Hz	1kHz	2kHz	4kHz	8kHz	Σ
Inlet - L _{PA5}	32	44	41	44	43	39	31	21	50
Outlet - L _{PA6}	58	68	62	66	65	62	54	44	72
Edited - L _{PA2}	39	27	40	57	56	55	49	37	61

The sound pressure level was determined for the conditions distance from the fan 3m, slope factor Q: 2, sound wave disturbance, equivalent absorption area 200m² Sabine

Nominal parameters

Maximum flow	Q _{MAX}	4000	m ³ /h
Static pressure maximum	Δp _{MAX}	800	Pa
Nominal power	P _{NOM}	1000	W
Nominal speed	n	1435	rpm
Nominal current	I _{NOM}	2.5	A
Nominal voltage	U _{NOM}	230	V
Number of phases	~	1	
Nominal frequency	f _{NOM}	50	Hz
Sound pressure level from the housing	L _{PA2}	49	dB(A)
Diameter	Ø	450	mm
Profile for rectangular connections	AxB	555x380	mmxmm
Unit weight	m	195	kg
Minimum operating temperature	t _{OPmin}	-20	°C
Maximum operating temperature	t _{OPmax}	40	°C
Maximum medium temperature	t _{MEDmax}	40	°C
Maximum ambient temperature	t _{AMBmax}	40	°C
Capacitor capacitance	CAP	10	µF
Capacitor voltage	U _{CAP}	400	V
Number of motor poles	pole	4	x
Motor type		AC	
Type of motor control		V	
Motor protection		TEAO	
Motor insulation class		F	
Motor protection class		IP44	

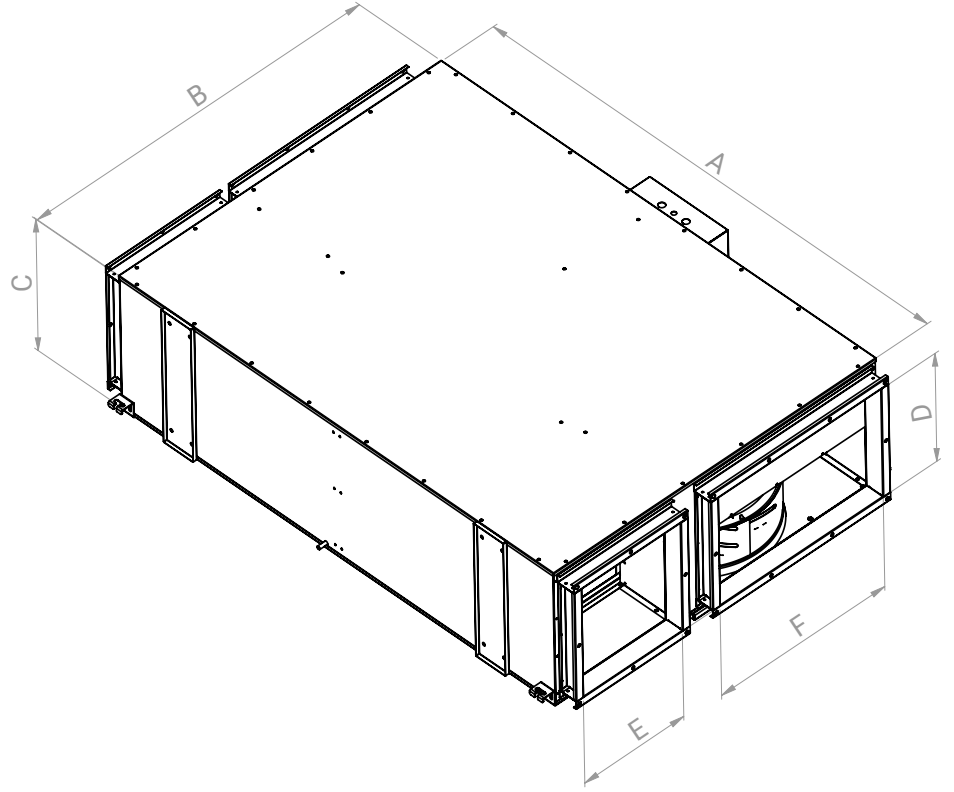
**Dimensions [mm]**

A	B	C	D	E	F
1700	1200	475	380	400	555

Device Components and Material Properties

The body is manufactured from galvanized sheet metal. Some of the fans of the BGK are made of high quality galvanized steel which is resistant to corrosion and some models are made of aluminum material to meet their performance requirements. All models have an external rotor motor with closed structure. The device is capable of handling air at max. 40°C. It consists of high efficiency plate heat exchanger, external rotor motor plug fan, filters and control panel components. An electric heater is available as an option.

Device Structure

Polyethylene insulation material is used for sound insulation and thermal insulation of the device body. There is a condensation pan designed to drain the condensate on the heat recovery exchanger.

Speed Control

Heated electric heater, low and high limit safety temperature thermostat.

Benefits

By means of the heat exchanger, the heat is transferred by means of heat exchanger without the mixture between the exhausted air and the fresh air taken from the outer space, pre-heating in winter conditions and pre-cooling in summer conditions. Since no extra energy is consumed in the meantime, some of the energy to be consumed for heating or cooling the fresh air is obtained from the indoor or outdoor air. Due to the recovery of exhaust heat, it reduces the initial investment and operating costs of air conditioning systems. The speed can be adjusted via the control panel. Easy access to plug fans and filters.

Usage Areas

School, hotel, shopping center, business centers, villa, hospital etc. structures where high amounts of fresh air are needed; It is used in cases where air freshening and air conditioning is desired to be done in an efficient way.

Accessory list

BSC-2
Speed control devices

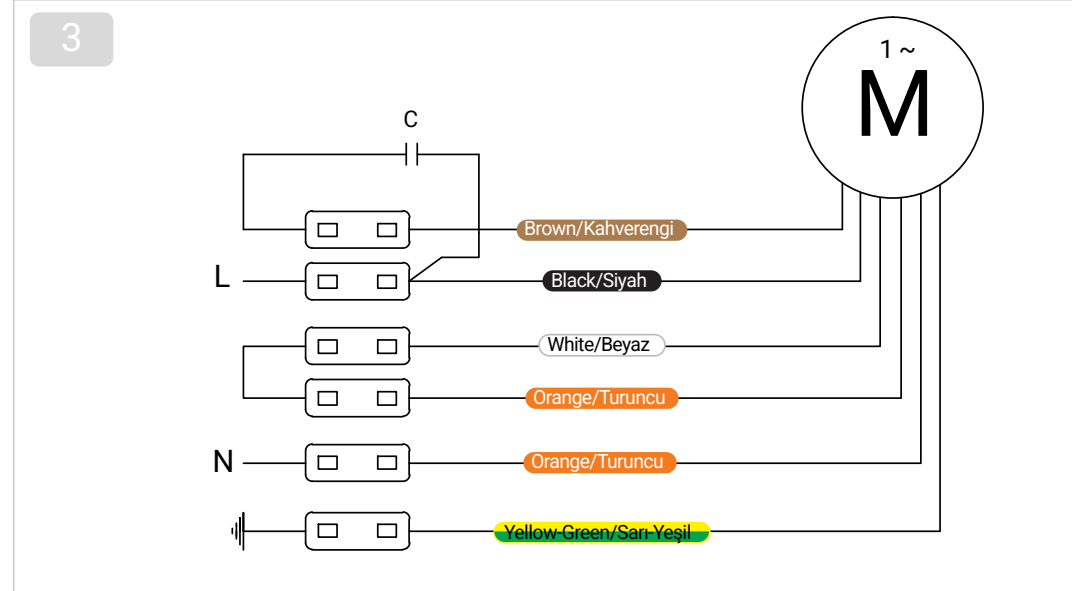
Electric connection diagram**Support/Files**

- <https://www.bvnair.com/fansecim/data/f.php?path=revit%2FBGK.rfa>
- https://www.bvnair.com/fansecim/data/f.php?path=dimension%2FBGK_montage1_drawing.pdf
- https://www.bvnair.com/fansecim/data/f.php?path=dimension%2FBGK_montage2_drawing.pdf
- https://www.bvnair.com/fansecim/data/f.php?path=manual%2FBGK_manual.pdf
- https://www.bvnair.com/fansecim/data/f.php?path=certificate%2FEAC_RU.pdf

